

Objective of the paper: to provide original inputs and elements of return of experience for the designers of a breeding blanket for DEMO from the current TBM systems design activities.

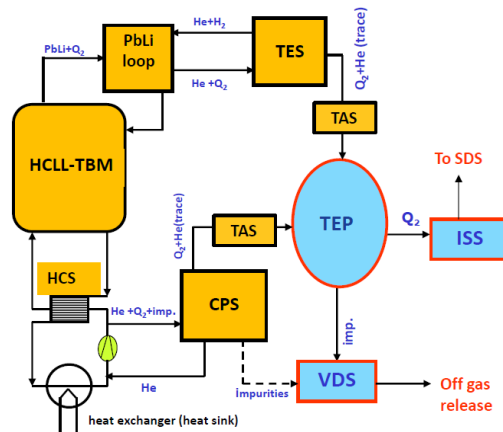

HCLL Test Blanket System

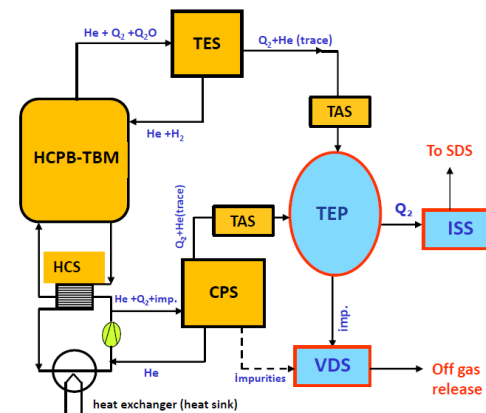

HCPB Test Blanket System

- The design of HCLL and HCPB-TBS has completed its conceptual phase. Already at this stage, the return on experience for the DEMO breeding blanket design is relevant in different ambits.
- Preliminary lessons learned for the breeding blanket designers deal with the implementation of the TBS licensing procedure, the design of the safety functions with the related impact on the instrumentation integration, the design of instrumentation for the different functions (safety, investment protection, conventional control) and the impact of the integration of the TBS in the ITER environment on several design aspects: in this paper the example of the management of the tritium contamination in the areas hosting the breeding blanket systems has been described.
- The design provisions described in this paper have been implemented in the European TBM project to solve several issues related to the above mentioned items. Based on the experience gained in conducting the TBS design, specific recommendations are given in this paper to the DEMO designers in order to guarantee a consistent approach to the breeding blanket design from the early stage.