

Dynamics of Tungsten Erosion under ELM-Like Intense Heat Loads

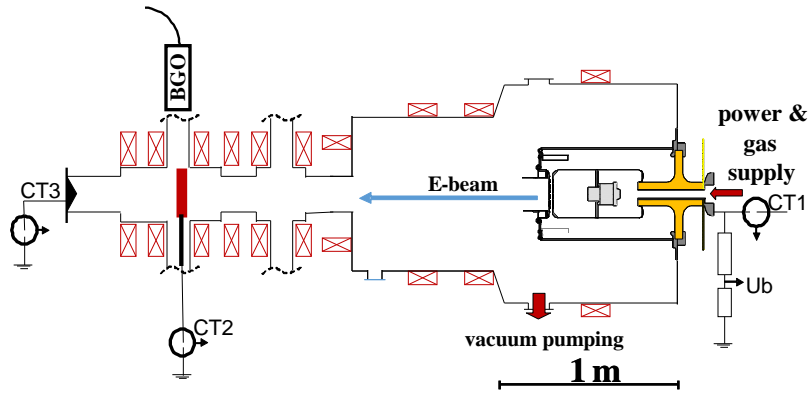

Electron Beam Based Test Facility for Observation of Dynamics of Tungsten Erosion under Intense ELM-like Heat Loads

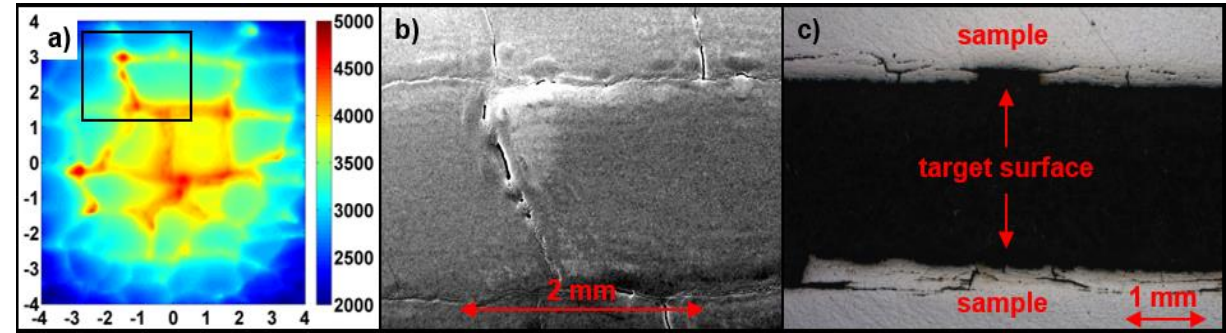

Observation of overheating near underlying (parallel to surface) cracks. Temperature distribution (a); SEM (b); microsection (c)

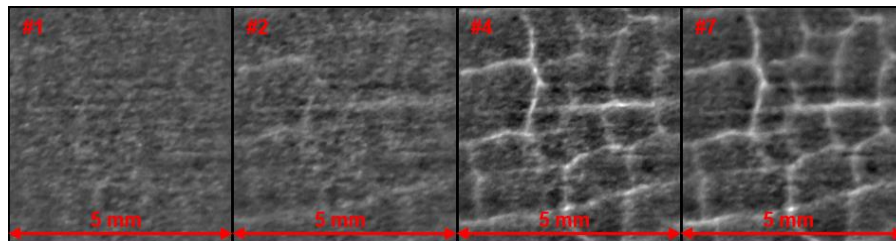

Thermal images of the cracks development during series of transient heat loads

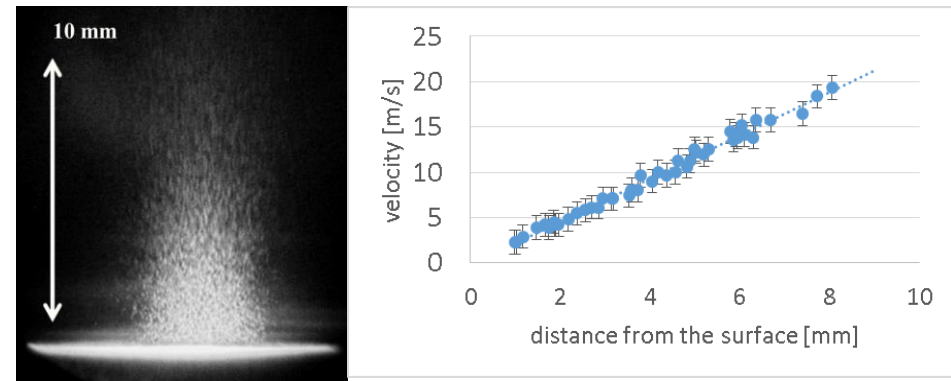

Observation of ejected particles and “Hubble’s law” of particles expansion