

Mission and Configuration Studies for a U.S. Sustained High-Power Density Tokamak Facility*

**J.E. Menard, T. Brown, B. Grierson, R. Maingi,
F. Poli, C. Rana, Y. Zhai, W. Guttenfelder**



R.J. Buttery, P.B. Snyder



*This work was supported by US DOE Contract No. DE-AC02-09CH11466
and the DOE Laboratory Directed Research and Development program.



- U.S. fusion community supports Fusion Pilot Plant (FPP) mission:
 - Produce net electricity from fusion
 - Establish capability of high average power output
 - Safe production and handling of T, feasibility of a closed fuel cycle
- Reduced-cost tokamak FPP may be feasible through compactness
- Novel high-B, high-J magnets pursued by several groups
 - Standard aspect ratio ($A \sim 3$), pulsed tokamak pursued by CFS
 - Aspect ratio $A \leq 2$, non-inductive pursued by Tokamak Energy
- Compact + steady-state + high-power integration challenge
- Sustained high power density (SHPD) facility to address challenge



- Present and near-term planned facilities do not access the FPP regime of combined high self-driven current + high core plasma pressure + high divertor parallel heat flux

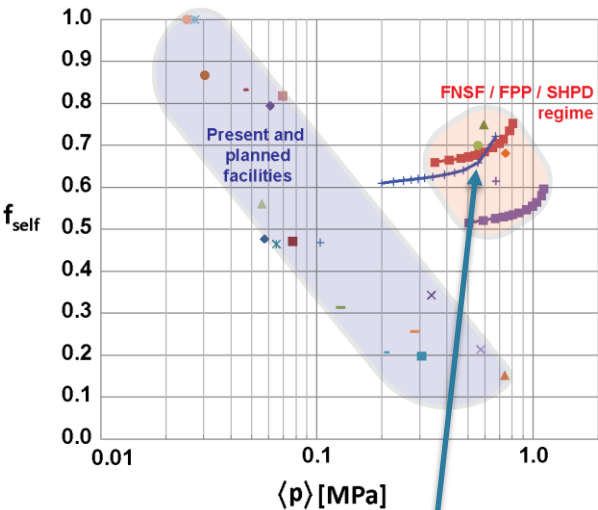

$f_{BS} = 60-80\%$
 $\langle p \rangle = 0.3-0.8 \text{ MPa}$
 3-10 \times present/planned at high f_{BS}

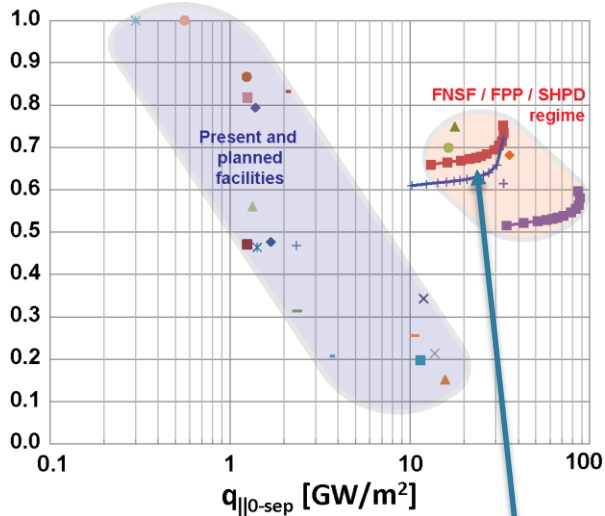

$q_{||0-sep} = 10-30 \text{ GW/m}^2$
 3-8 \times present/planned at high f_{BS}

- ▲ FNSF (A=4)
- CAT (A=3.1)
- + ARC (A=3.0)
- Low-A Pilot (A=2.0)
- Pilot scan: ITER 98y2
- Pilot scan: Petty08
- SHPD: R=1.2m, Paux=50MW

- x W7-X
- o LHD
- NSTX-U IP=1MA
- DIII-D IP=1MA
- x NSTX-U IP=2MA
- + DIII-D IP=2MA
- KSTAR
- ▲ EAST
- C-Mod
- x ADX
- ◆ AUG
- JET
- ◆ JT-60SA (Fully Non-Inductive)
- JT-60SA (Inductive)
- DTT (Italy)
- ITER baseline
- x EU Demo1
- ▲ SPARC (JPP 2020)

Need to bridge $nT\tau_E$ and τ_{duration} gap to FPP



4

- Gap: 2-3 orders of magnitude in both pulse duration and $nT\tau_E$
- Baseline SHPD device to narrow $nT\tau_E$ gap, Upgrade to narrow τ_{pulse}

Adapted from Fig. 4.2 of NASEM report “[Bringing Fusion to the U.S. Grid](#)” (2021)

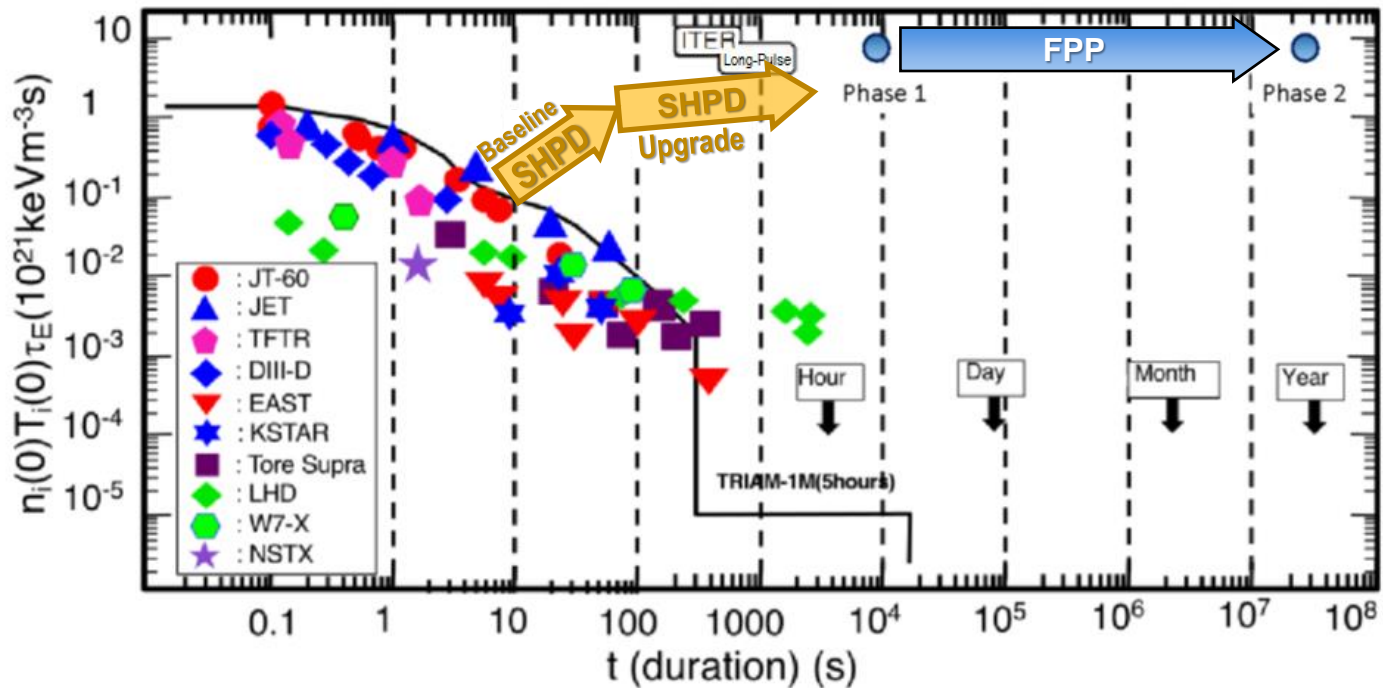

Systems, Scenario, and Device Configuration Modelling



What might a FPP and SHPD look like?

Informed by OD scaling models for physics, engineering

Define device performance targets

OD model to ID size, B, power, ...

Layout: TF, PF, OH, vessel, blankets, ...

Free-boundary equilibrium calcs

Engineering design/analysis: structure, coils, in-vessel, ...

Define heating and current drive actuators, access

Transport and stability for profiles w/ fidelity hierarchy: scaled, reduced, full

Divertor, first wall, power loading, heat-flux profiles

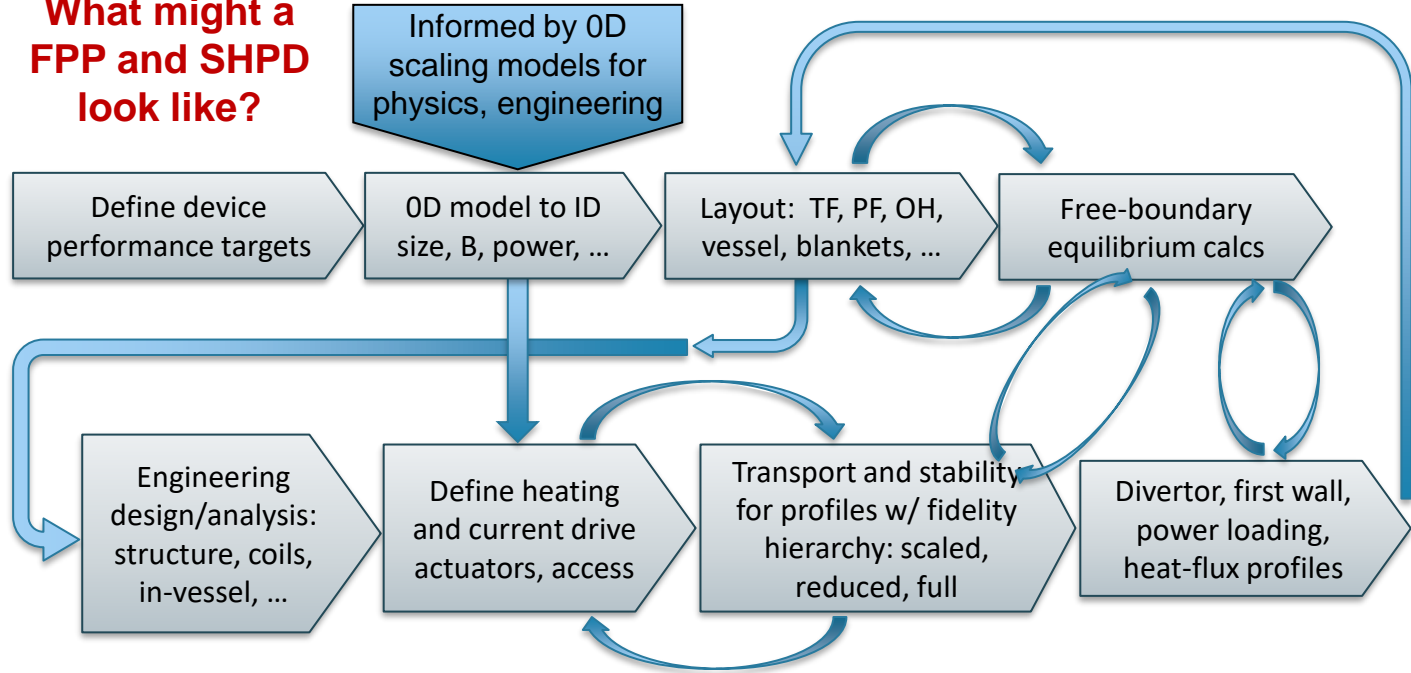



Pilot Plant example:

- **Net electric power = 100MWe**
- 100% non-inductive current drive
- Tritium breeding ratio ≈ 1
- ReBCO TF lifetime = 10 FP-years
 - $B_{TF-max} = 18T, J_{WP-TF} = 50 \text{ MA/m}^2$

- $A \approx 2-2.4$ reduces TF volume by factor of 1.5-2 \times vs. standard A
 - May reduce TF cost (TBD)

- Low-A also reduces size, space available for central solenoid
 - Pulsed operation favors high A
 - $A < 2 \rightarrow$ partial non-inductive ramp



Total TF coil volume

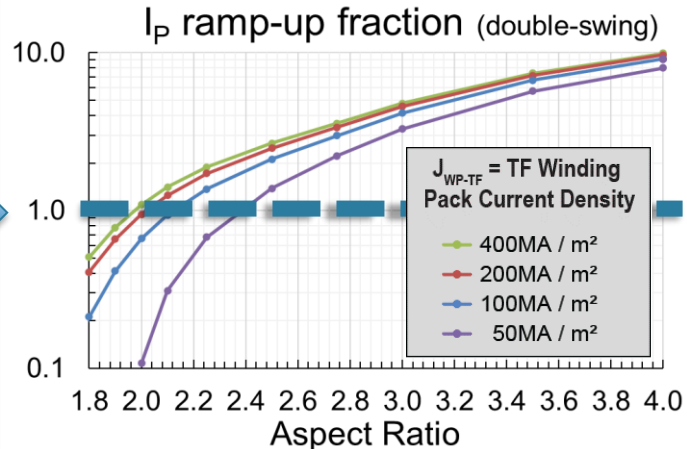
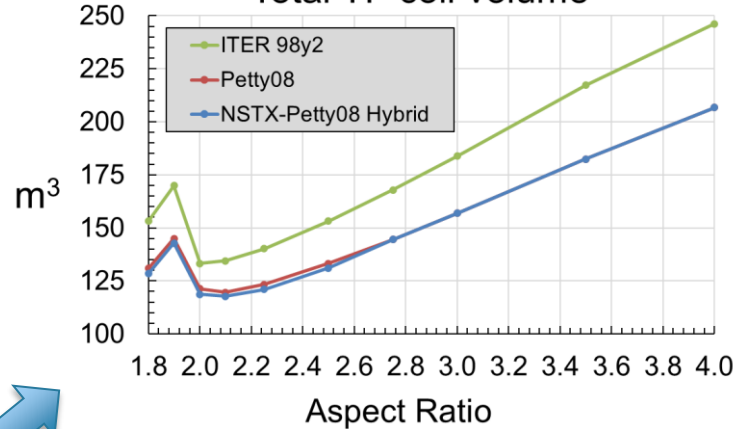



- SHPD overlaps FPP values of:
 - Average pressure
 - Separatrix parallel heat flux
 - Surface-average heat flux P_{heat}/S
- High-A, small radius SHPD would have excessive P_{heat}/S ($3\times$ FPP)

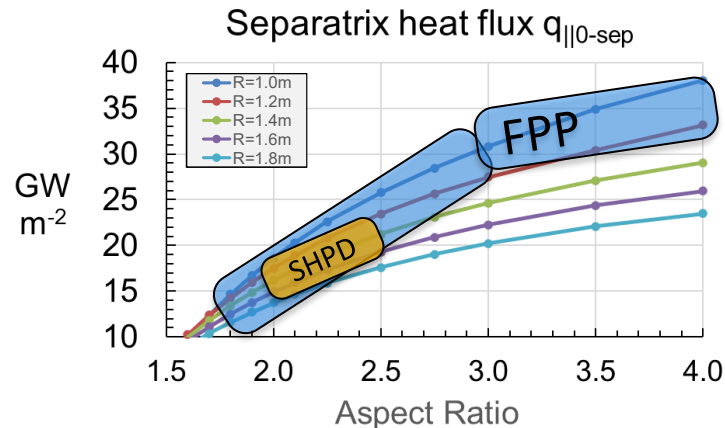
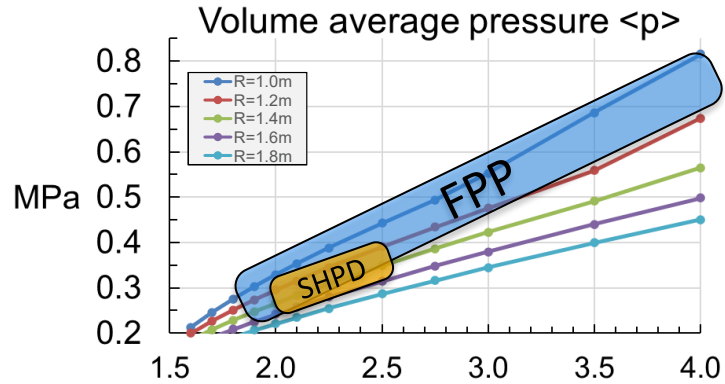
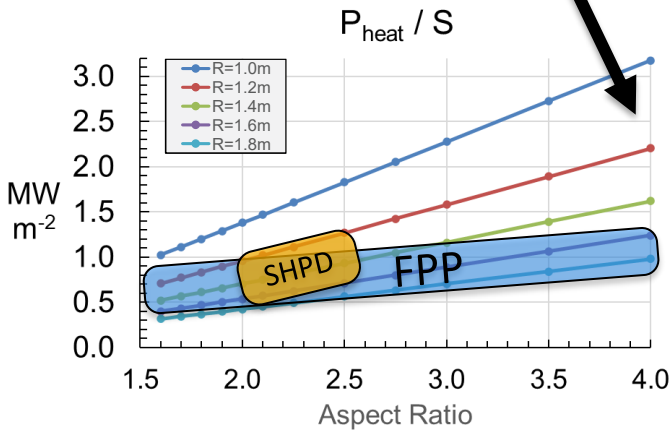



**Aspect ratio scan
Fixed shape
 $\delta=0.6, \kappa=2.2$**

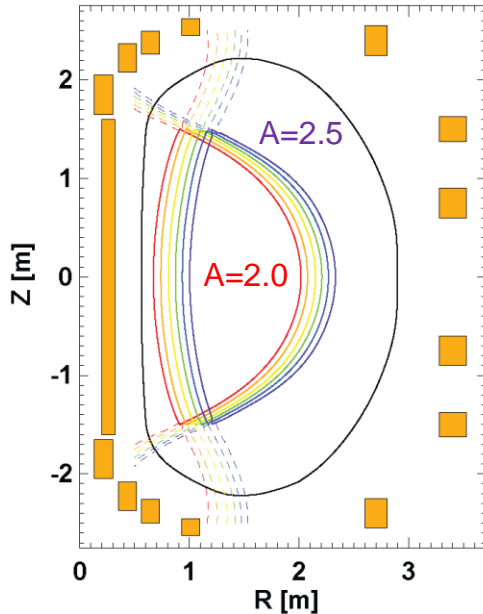

**Aspect ratio scan
Fixed inner gap
 $\delta=0.5-0.6$**

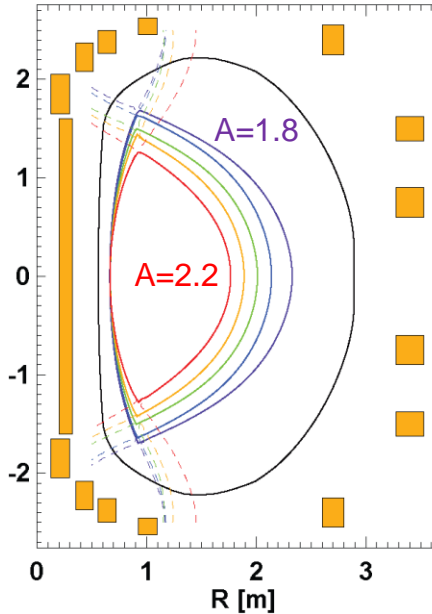

**Low A
Positive and
negative δ**

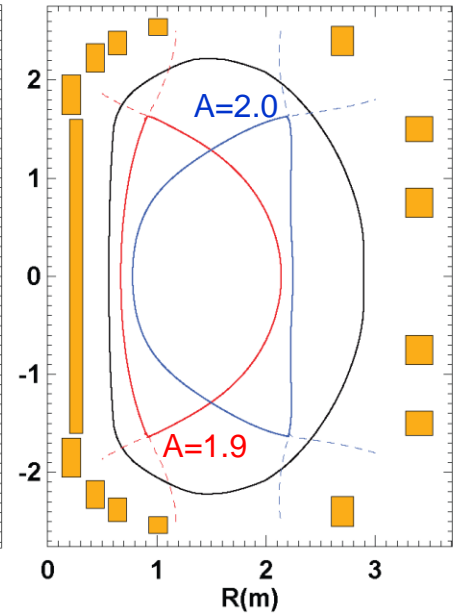

- Present PF set can access $A=1.8-2.5$ in single device
- **Caution:** Need to assess in-vessel component and exhaust compatibility
- **Future:** Explore long-leg / super-X / X-point-target at higher $A=2.3-2.5$

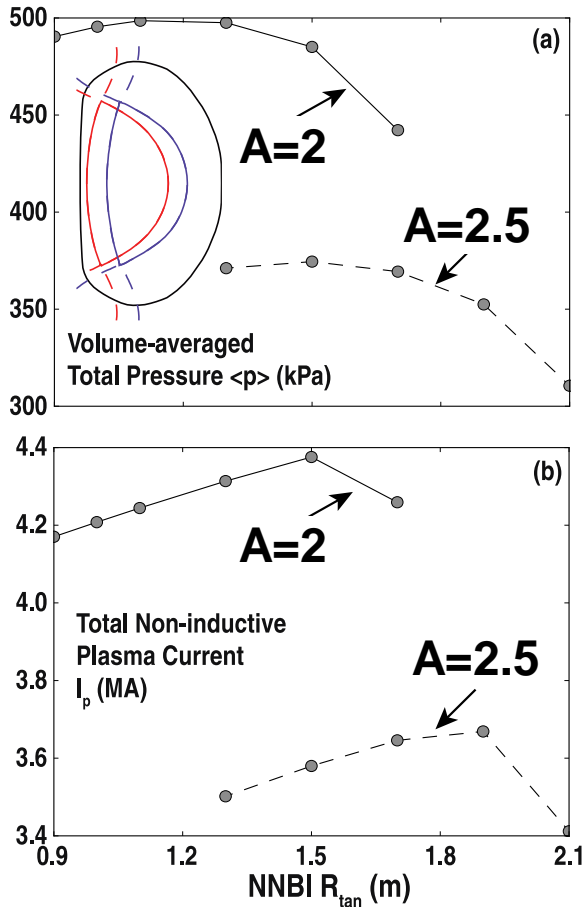

TRANSP^{PPPL} OMFIT

- **Model assumptions:**
 - D-NNBI at 0.5 MeV, $f_G = 0.7-0.8$
 - TRANSP, NUBEAM for H&CD
 - EPED1-NN for pedestal
 - GLF23 for core transport
- **A=2.5 projections:**
 - $R_0 = 1.66\text{m}$, $B_T = 4.4\text{T}$, 20MW
 - $\langle p \rangle = 0.37\text{ MPa}$
 - **Approx. $\frac{1}{2}$ of FPP at A=2.5-3**
- **A=2.0 projections:**
 - $R_0 = 1.34\text{m}$, $B_T = 5.4\text{T}$, 20MW
 - $\langle p \rangle = 0.5\text{ MPa}$
 - **Comparable to FPP at A=2.0**

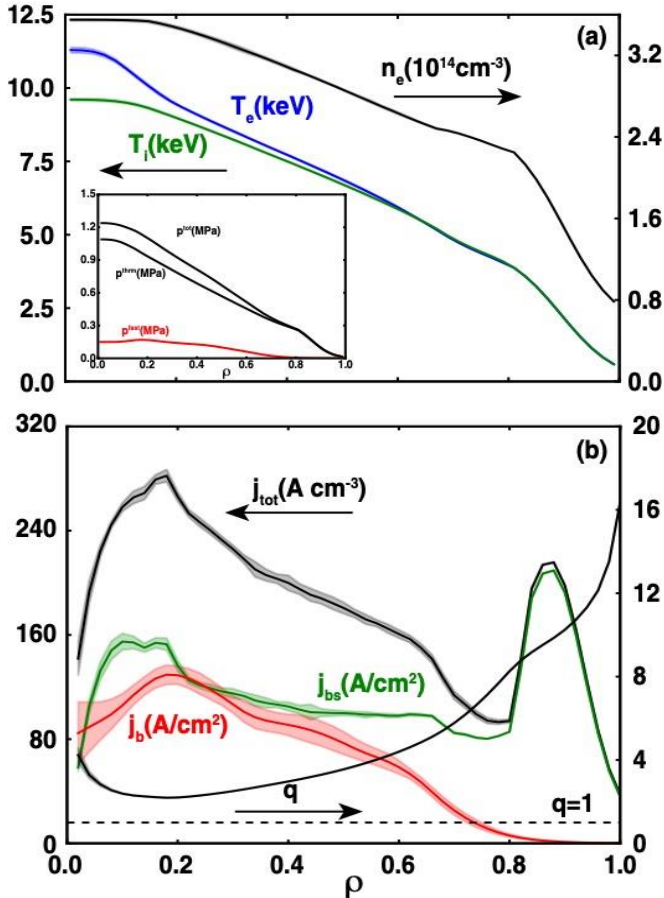

- $R_0=1.34\text{m}$, $B_T=5.4\text{T}$
- $P_{\text{aux-NNBI}} = 50\text{MW}$
- GLF23 + EPED1-NN + NSTX-like pedestal width scaling:
 - $T(0) \approx 10\text{keV}$
 - $I_p = 4.5 \text{ MA (100\% NI)}$
 - $\langle p \rangle = 0.54 \text{ MPa}$
 - $\beta_N = 3.7$, $\beta_t = 4.8\%$, $\beta_p = 1.9$
 - $f_G = 0.88$
 - $q_{\text{min}} = 2.2$
 - $f_{\text{BS}} = 0.69$
 - $H98(y,2) = 1.65$
 - $Q_{\text{DT}}(\text{thermal}) \sim 0.63$

Example Device Configuration

Example SHPD features

- 10 HTS superconducting TF
- $B_{T0} = 5.5$ to 6.0 T at $R_0 = 1.2$ m depending on J_{WP} of TF
- Superconducting solenoid for I_p ramp-up, flux depends on J_{WP-TF}
- Double null
- Outboard test blankets possible
- Vertical maintenance
- High-Z solid and liquid-metal walls

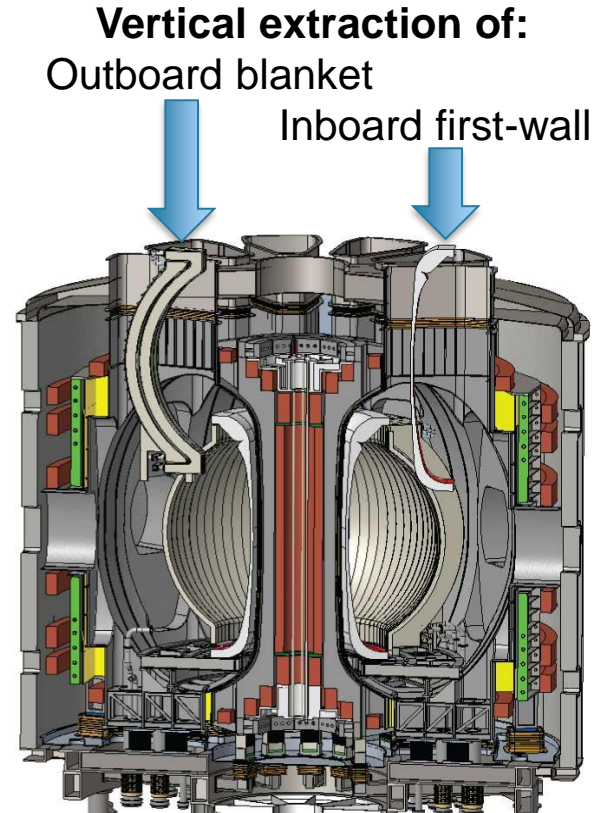

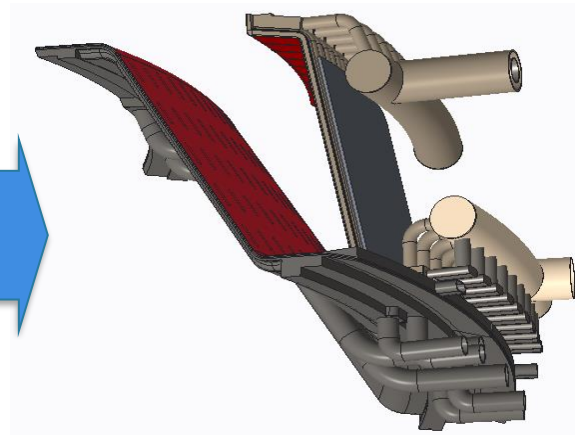
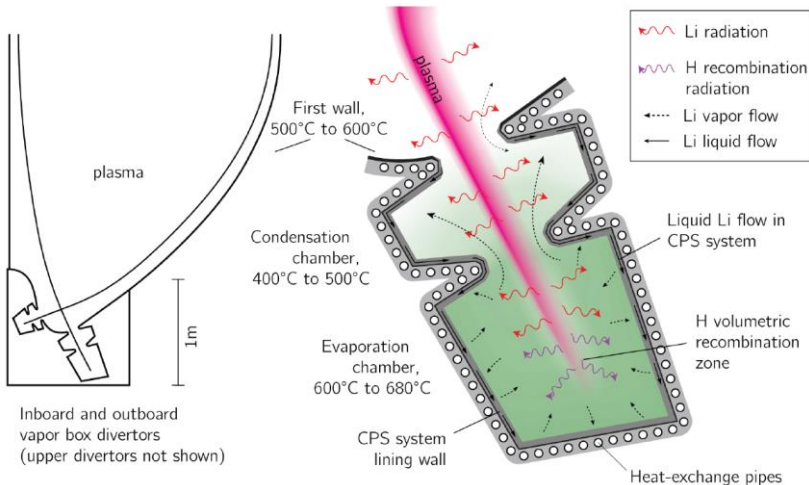

Idea pioneered by R. Goldston

Jacob Schwartz – PhD Thesis
September 2020
Princeton University

Continuing work by E. Emdee

Vapor box module (w/o internal baffles)
with lithium manifolds included
Much more R&D to do!

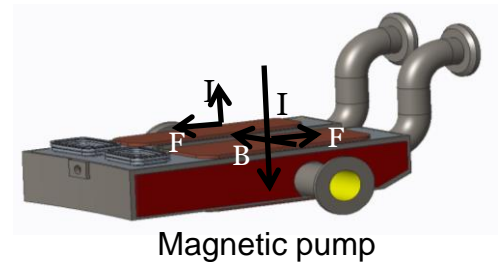
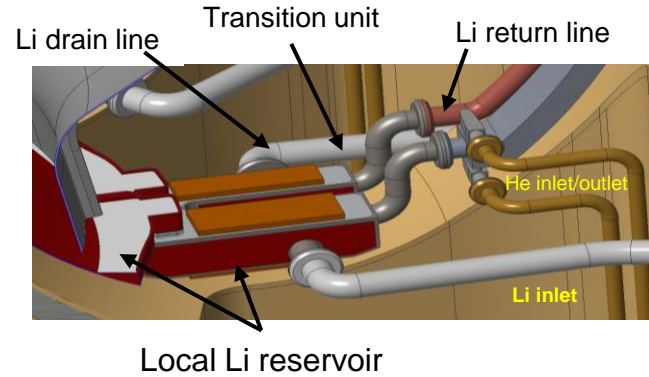
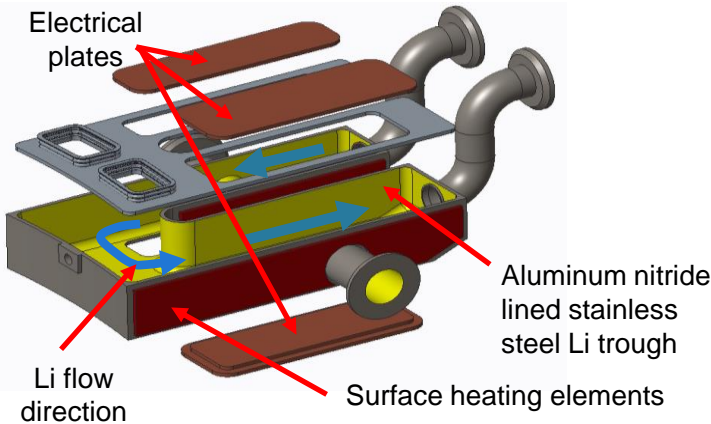

- 5-10 m/s Li flow velocity for 10 MW/m² convective heat removal
- Combinations of vapor box and fast-flow also being explored

Initial Engineering Analysis

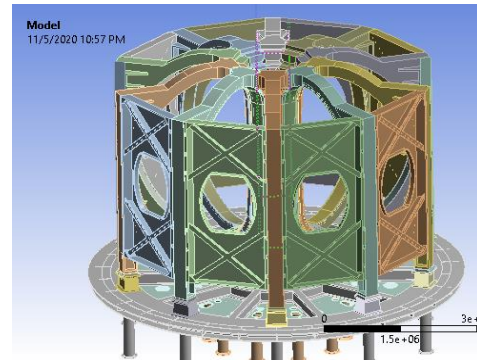
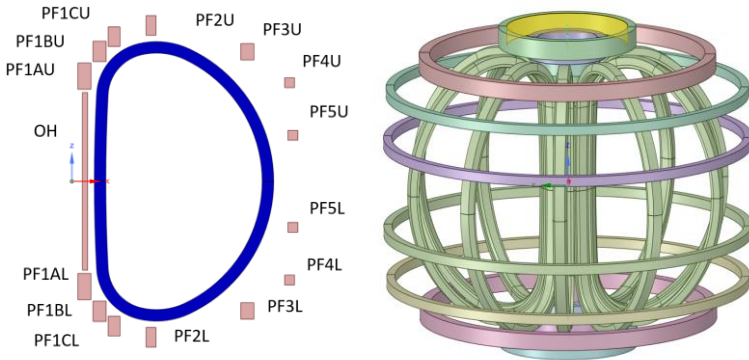

Electromagnetic structural load
TF coils + casings + PF coil load
Peak Stress= 380MPa
is within allowables

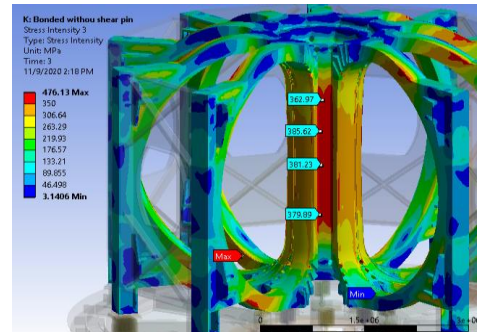

Total Deformation

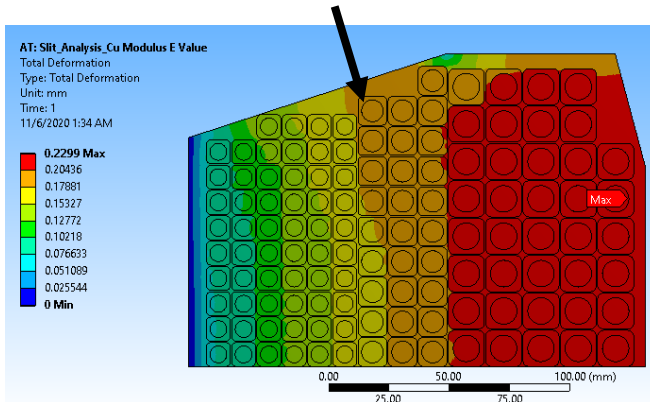

Overall Stress Intensity

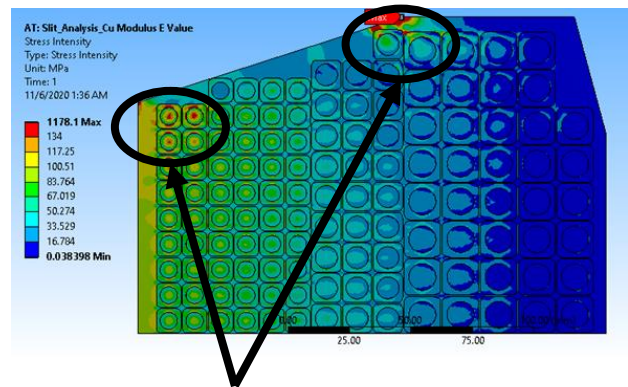

Max stress concentration areas
in bundle corner regions

**Deformation and stress through bulk of coil are within allowables,
but some regions near casing corners need further optimization**

No shear pins:

Large sliding and gap opening TF-to-TF

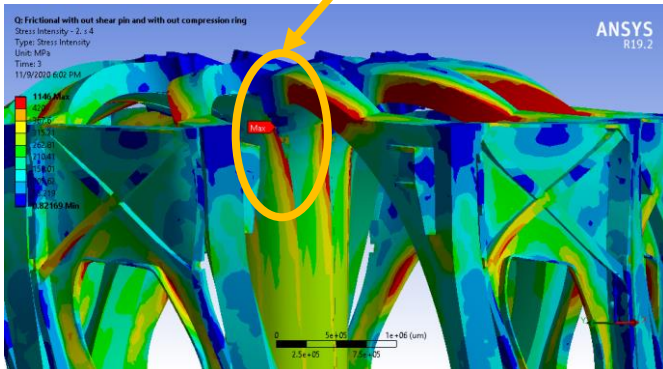

With shear pins:

Small sliding and gap opening TF-to-TF

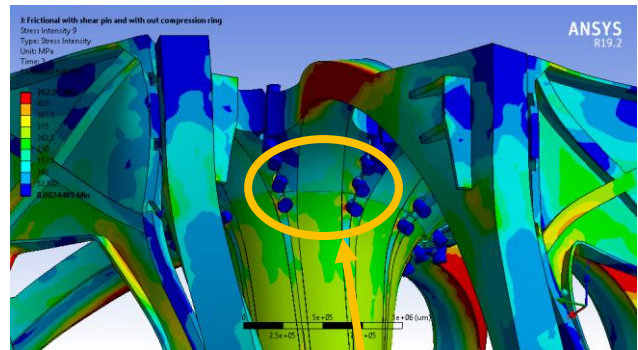

1st shear pin region take max load

Compression ring + shear-pins promising combination to reduce sliding and gaps to acceptable levels



- Present/near-term planned facilities will not access FPP regime
- Need dedicated facility (or FPP itself) to simultaneously explore:
 - High fraction of self-driven current
 - High core plasma pressure
 - High surface-average and divertor parallel heat flux
- $R=1.4 \pm 0.2\text{m}$, $B = 4\text{-}6\text{T}$, $A = 2\text{-}2.5$, $P_{\text{H\&CD}}=50\text{MW}$ attractive for SHPD
- Systems studies and initial integrated predictive modelling indicate FPP regime should be accessible with the above SHPD parameters
- Initial device configuration and physics design integrates:
 - High current density and high B_{T} toroidal field magnets
 - Lower aspect ratio / strong shaping to maximize f_{BS} and pressure
 - Liquid metal systems (divertor, first wall, blankets) to prototype FPP
- Engineering calculations show pre-conceptual design is feasible