

ITER-TBM Program activities in Europe, China and India

Presented by:

E. Rajendra Kumar

Indian TBM Team

Institute for Plasma Research, India

Contributors:

Aiello Giacomo, Europe TBM Team

Kaiming Feng, China TBM Team and

E. Rajendra Kumar, India TBM Team

 **Please note:** Dedicated posters are presented by individual authors of the following papers:

1. **FTP/4-4Ra** Status of LLCB TBM R&D Activities in India
2. **FTP/4-4Rb** Activities on the Helium Cooled Lithium Lead Test Blanket Module for ITER
3. **FTP/4-4Rc** Current Progress of Chinese Solid Breeder TBM

This presentation will try to focus on the contents provided in these papers as presented for this conference.

TBM Program in ITER

TBM = Test Blanket Module

- ✚ Tritium Breeding Blankets are complex components, exposed to severe working conditions, needed in DEMO. But, not present in ITER → ITER is a unique opportunity to test the mock-up of DEMO blanket in a DEMO-relevant conditions.
- ✚ One of the ITER missions : “ITER should test tritium breeding module concepts that would lead in a future reactor to tritium self-sufficiency, the extraction of high grade heat and electricity production. All the activities related to this mission forms the “**TBM Program**”.
- ✚ All ITER Members (**CN, EU, IN, JA, KO, RF, US**) participate in the TBM Program. Of them, **CN, EU, IN, JA and KO** planning to test their TBMs in ITER.
- ✚ Each TBM Set (TBM + Shield Block) and the associated ancillary systems (cooling system, Tritium extraction system, measurement systems, etc..) are defined as Test Blanket System (TBS)

TBM Assembly in ITER

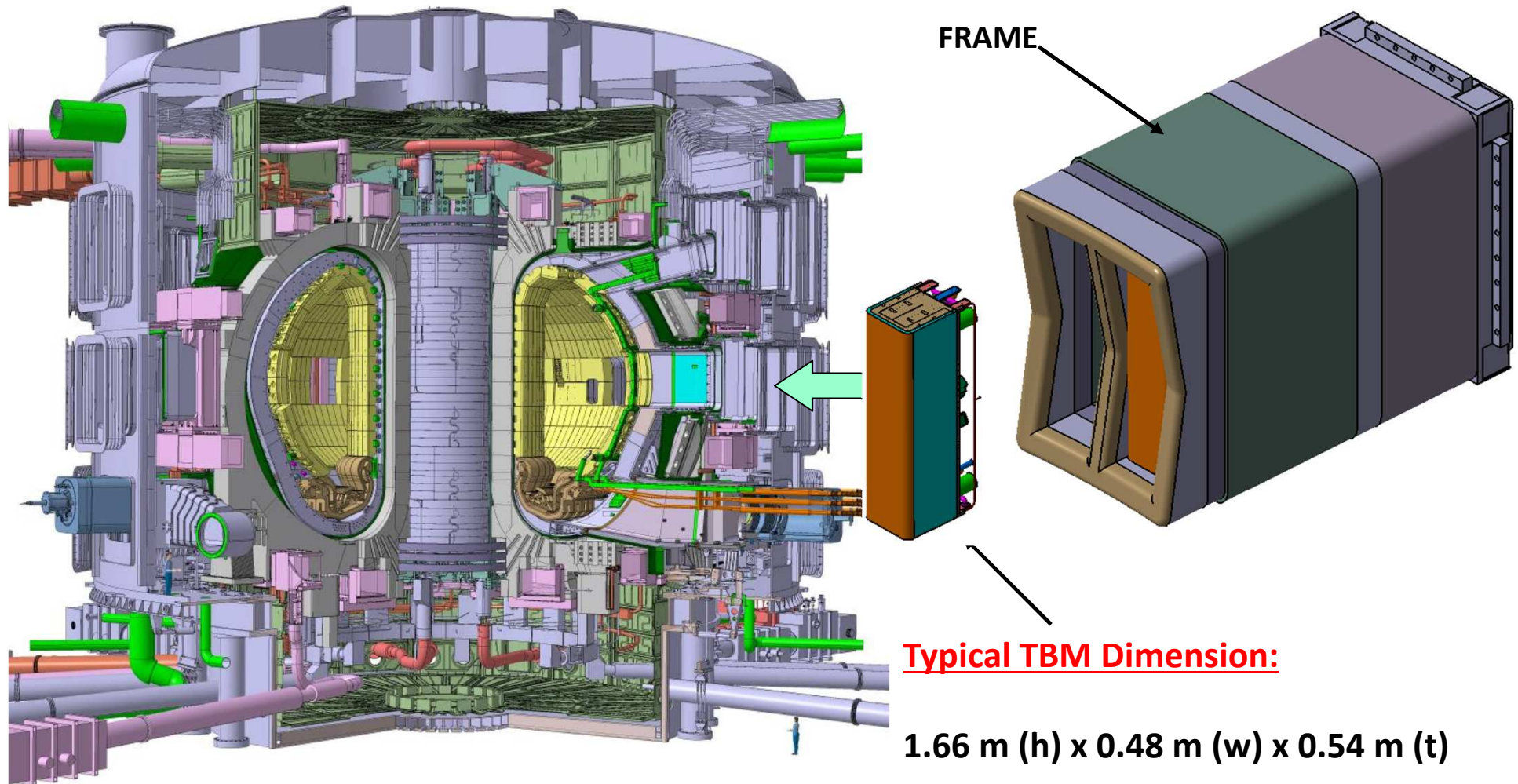

Each TBM will be tested in one half of Radial Port of ITER

Test Blanket Systems Testing in ITER

- ✓ 3 ITER equatorial ports (opening of 1.75 x 2.2 m²) allotted for TBM testing
- ✓ TBMs installed within a water-cooled steel frame (thick. 20 cm), half-port size → 6 TBMs

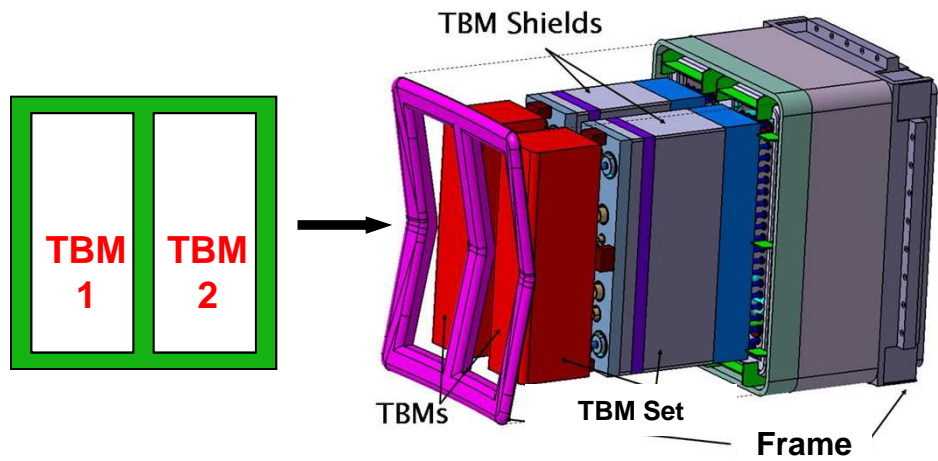

Exploded view of a TBM Port Plug

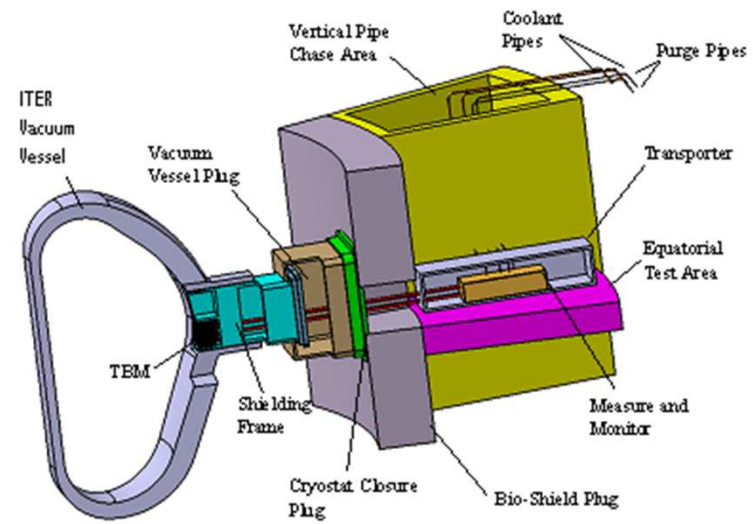
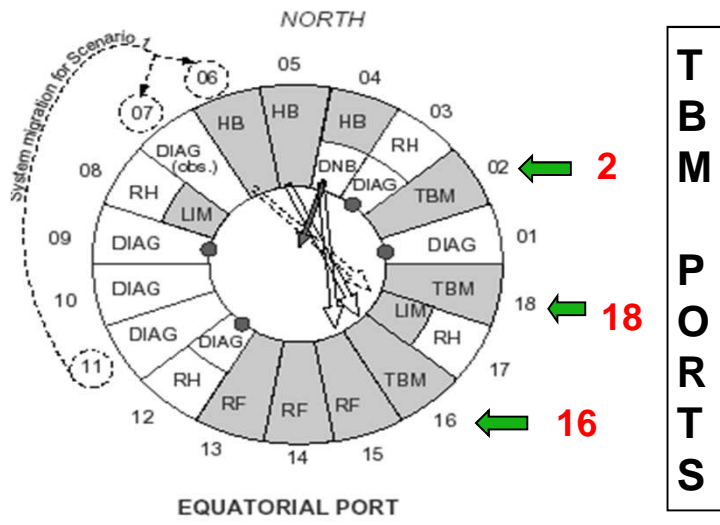

Example of Test Blanket Systems Locations

Test Blanket Systems in ITER

The 6 TBSs to be installed in ITER during H/He phase are the following:

(PM : Port Master, TL : TBM Leader)

Port No. and PM	TBM Concept	TBM Concept
16 (PM : EU)	HCLL (TL : EU)	HCPB (TL : EU)
18 (PM : JA)	WCCB (TL : JA)	HCCR (TL : KO)
2 (PM : CN)	HCCB (TL : CN)	LLCB (TL : IN)

HCLL : Helium Cooled Lithium-Lead,(Helium /Pb-Li);

HCPB : Helium Cooled Pebble Beds (Ceramics/Beryllium)

WCCB : Water Cooled Ceramic Breeder,(Ceramics / H₂O);

HCCR : Helium Cooled Ceramic Reflector (Ceramics/Beryllium/Graphite)

HCCB : Helium Cooled Ceramic Breeder (Ceramics / Be),

LLCB : Lithium-Lead Ceramic Breeder (Helium /Pb-Li + Ceramics)

In order to correctly represent the corresponding DEMO breeding blanket mock-ups, all the TBMs require to use **Reduced Activation Ferritic-Martensitic steels**

Licensing and Quality Plan for TBMs

- ✚ Being a part of ITER, TBMs should also go through the same process of licensing as ITER
- ✚ ITER Organization has included TBM descriptions in safety documents presented to French authorities. The TBSs are included in the ITER RPrS (Rapport Preliminaire de Surété)
- ✚ The present strategy for the TBM Program is to assume that all accidental sequences that could involve TBMs remain within the envelope cases assessed for ITER. This requires appropriate safety analysis.
- ✚ TBSs components should comply with rules for Pressurized and Nuclear Pressurized Equipment (ESP & ESPN rules) and SDC-IC. This requirement implies that TBSs design and manufacturing should be validated by a notified body.
- ✚ In the TBM Program, TBM parties are responsible for the functional specifications, design and manufacturing of the TBSs. IO is responsible for the operation.
- ✚ An Arrangement (TBMA) has to be signed between IO and each TBS IM responsible. In these arrangements, the details of the QA procedure and the Quality Plan (QP) will be mentioned.

European Helium Cooled Lithium Lead Test Blanket System (HCLL-TBS)

The European Helium Cooled Lithium Lead Test Blanket System (HCLL-TBS) in ITER

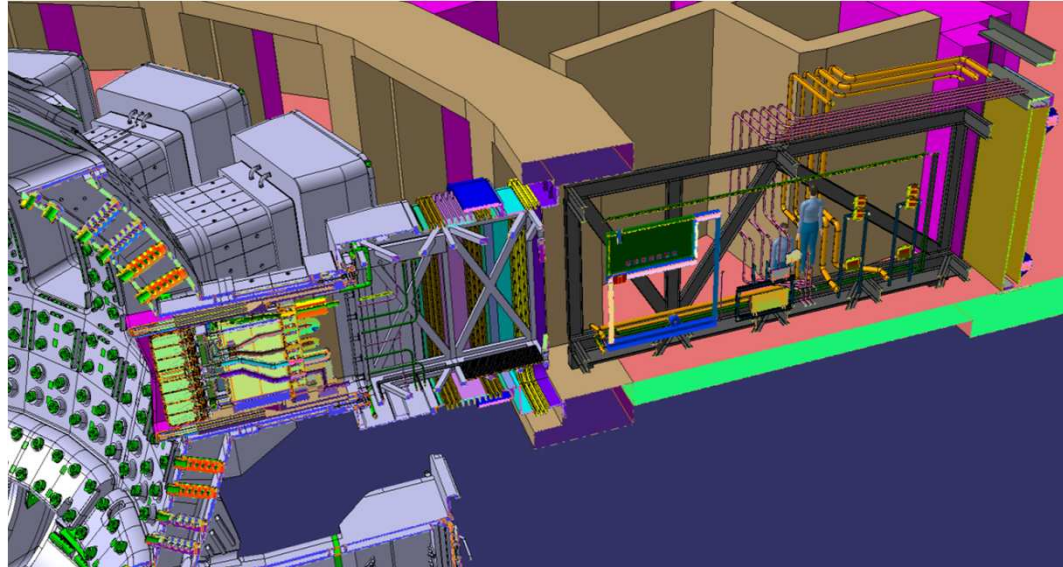

The HCLL blanket concept is based on the use of:

- **Liquid eutectic Pb-15.7Li** as breeder, neutron multiplier and tritium carrier
- **Helium** (8 MPa, 300-500°C) as coolant
- **Eurofer97**, a Reduced Activation Ferritic/Martensitic steel, as structural material

The corresponding Test Blanket Module (TBM) and its auxiliary systems will be installed in equatorial port #16 in ITER (shared by the two EU concepts)

The conceptual design of the HCLL-TBM

Maximum **geometrical similarity** between the design of the TBM and the **corresponding DEMO** modules.

Current developments:

- Compliance with regulation (PED, French ESPN order)
- Structural analyses under ITER pulsed plasma operation
- Fabrication and assembly techniques
- Integration of sensors

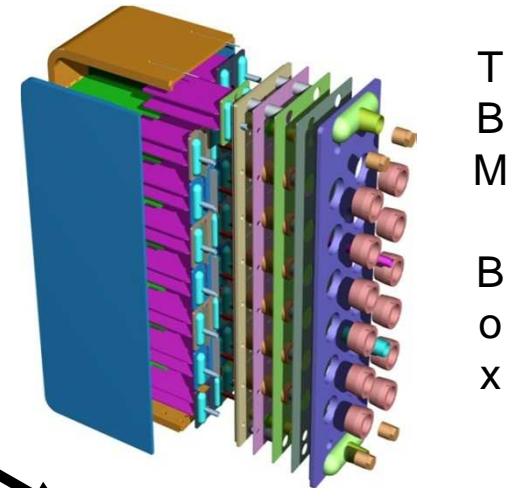

T
B
M

B
O
X

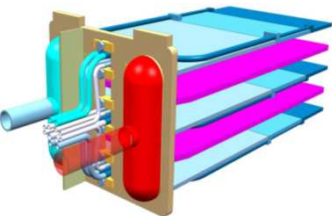
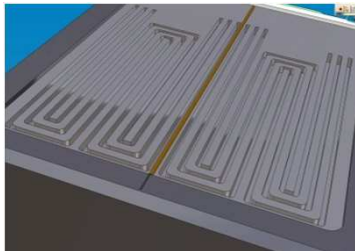

Examples of instrumentation layout

Two-step weld+HIP process

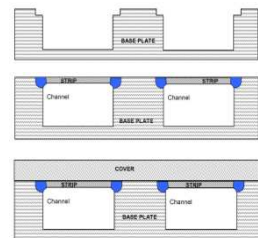

Welding table in CEA-Saclay



Eurofer97 subcomponents mock-ups

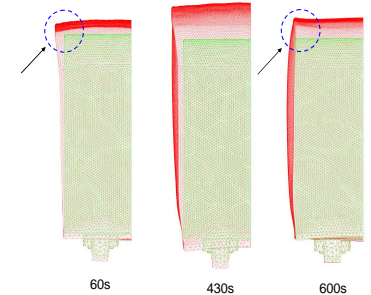
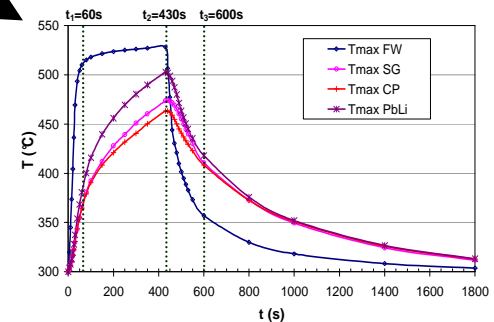

Thermomechanical cycling of the FW

The HCLL-TBM Ancillary Systems

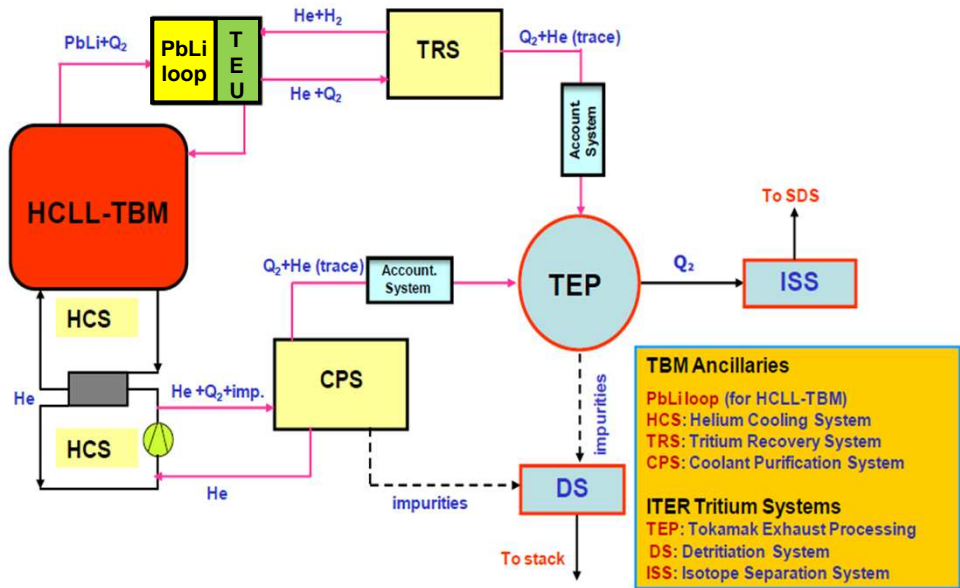

- Detailed PFD & P&ID of all subsystem have been developed
- Preliminary operation and maintenance plan have been produced
- Selection of industrial components available on the market has been done
- More experimental tests are needed for components not available on the market (mainly related to tritium technology)

The Tritium Extraction System : TEU+TRS

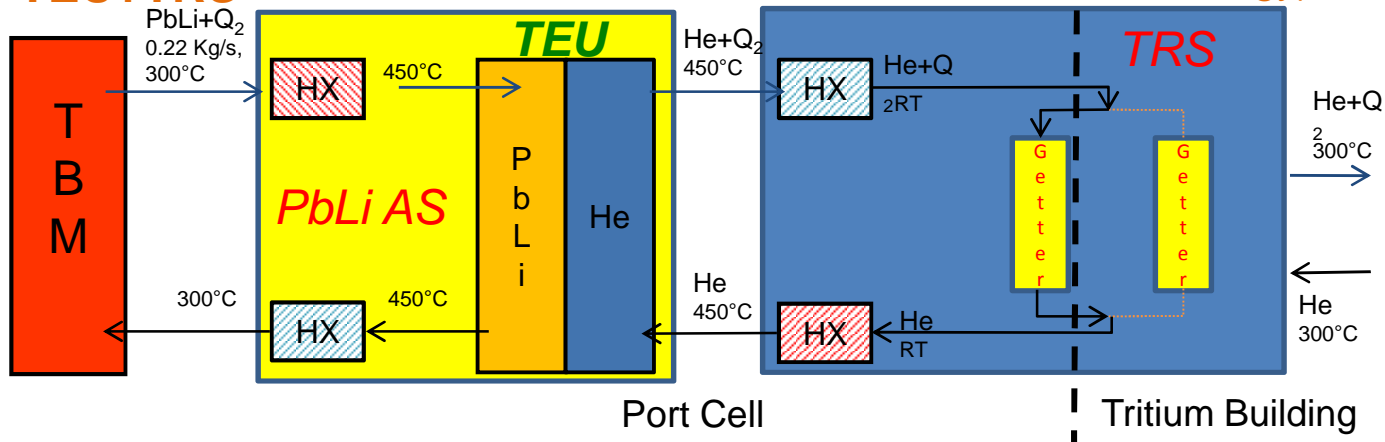

TEU: Gas Liquid Contactor (450°C, 40% efficiency)

TRS: 2 getter columns (ZrCo alloy) **working at room temperature.** One in adsorption, the other in regeneration to insure continuous operation.

HCLL TBS Integration in ITER

Integration of sub-systems in the AEU

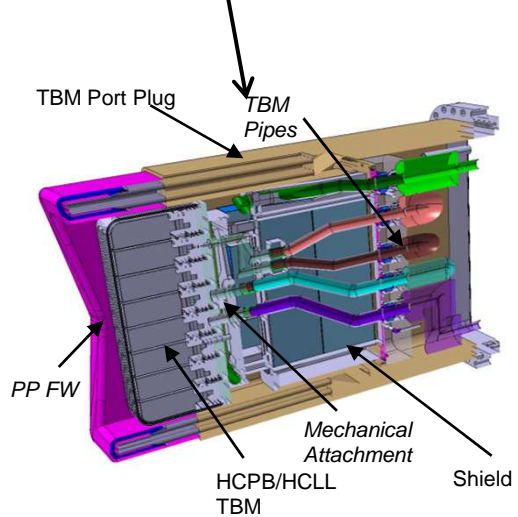
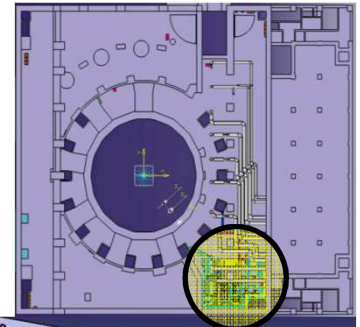
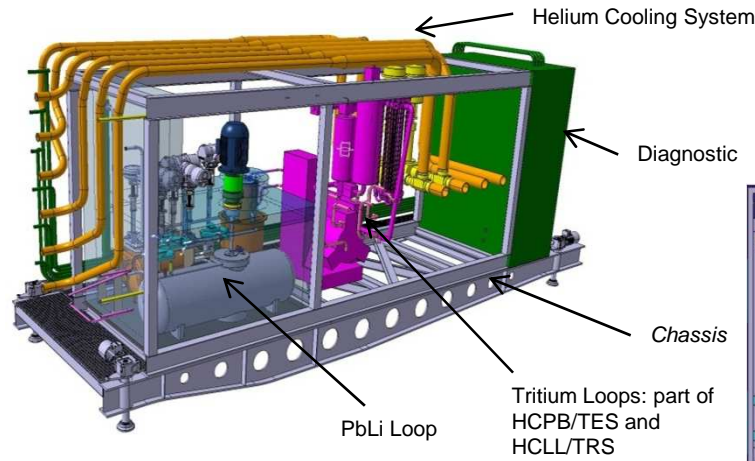
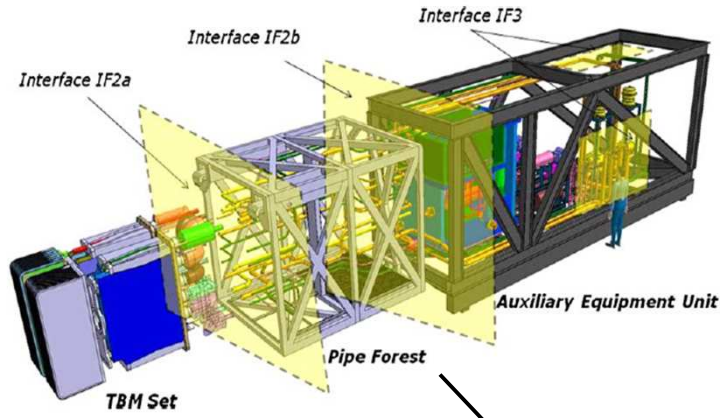

The TBM-Set: TBM+Shield

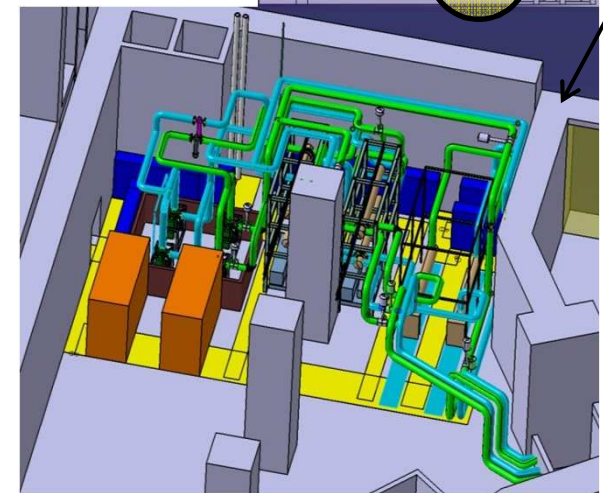
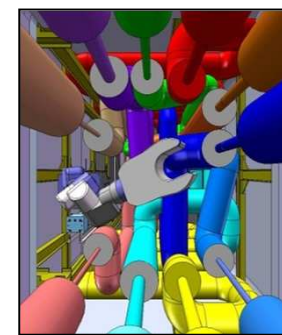
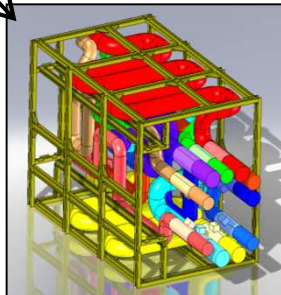

The TBM Experimental Programme

- A list of possible experiments to be performed in different fields (electromagnetics, neutronics, tritium generation/extraction, MHD, corrosion, etc.), during the different ITER phases, has been proposed .
- A preliminary work-plan aimed at filling the gap between the present R&D level and the required one has been defined. **Experimental campaigns are undergoing in several EU laboratories.**



PbLi loop at IPUL for corrosion experiments.



The MEKKA facility at FZK NaK loop for MHD experiments



The HEBLO/HETRA facility at FZK for investigation of heat removal from the FW



The CASPER facility at FZK tritium laboratory (tritium accountancy)

The TRIEX loop at ENEA for the development of the TEU

The DIADEMO facility in CEA for thermo mechanical testing of subcomponents



The HeFus3/EBTTF Facility in ENEA for thermo mechanical testing of full-scale TBM mock-ups

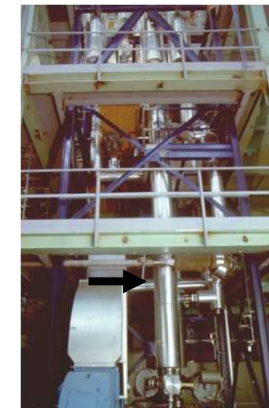

Chinese Helium-Cooled Ceramic Breeder Test Blanket System (HCCB-TBS)

CN-HCCB TBM

Basic design characteristics:

- TBM structure: Sub-module arrangement
- Structure material: RAFM (CLF-1);
- Tritium breeder: Li_4SiO_4 pebble bed, 80%Li-6 ;
- Neutron multiplier: Be pebbles bed;
- Coolant and purge gas: Helium gas
- Coolant pressure: 8MPa
- Coolant temperature: 300 °C(inlet) -500 °C (outlet)
- Tritium production ratio (TPR): 0.0505 g/d

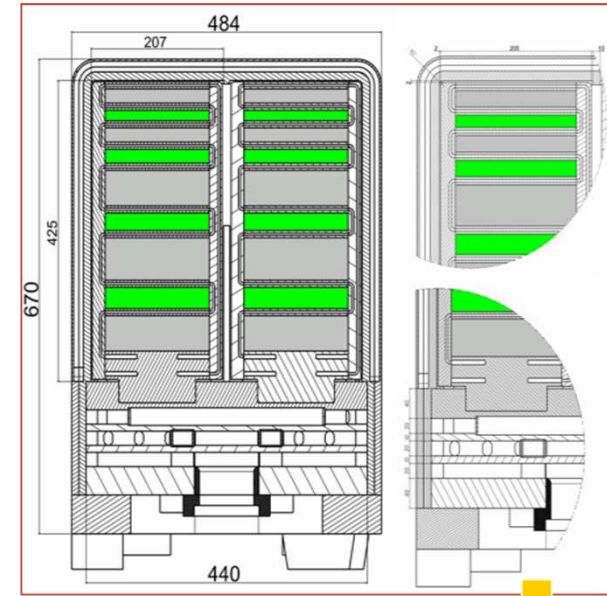

Cross-section of SB

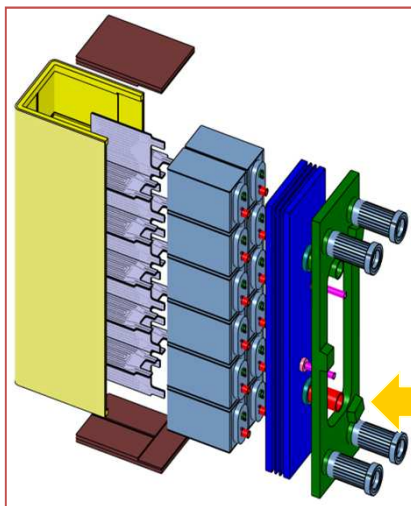

Integration View of CN HCCB TBM

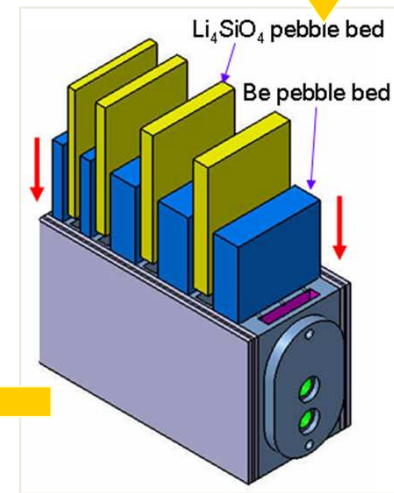
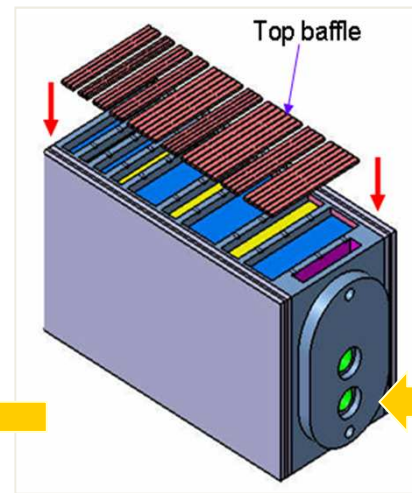
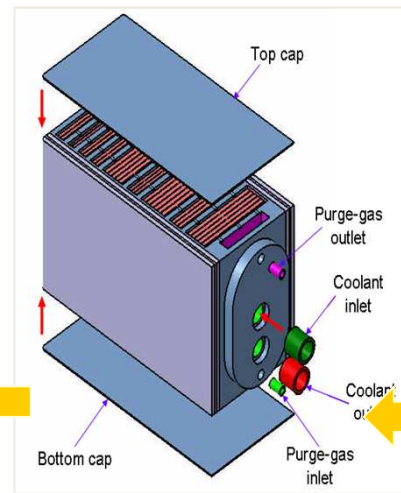

Assembly scheme of Sub-Modules

CN HCCB TBM Auxiliary Sub-system Design

Helium Cooling Systems (HCS)

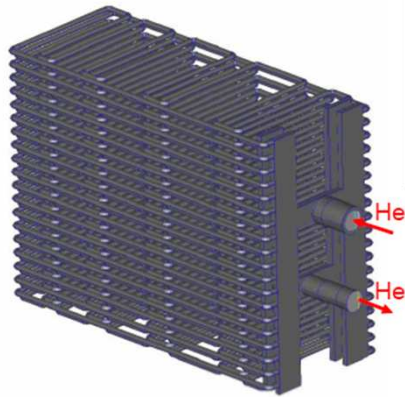

sub-module cooling tubes

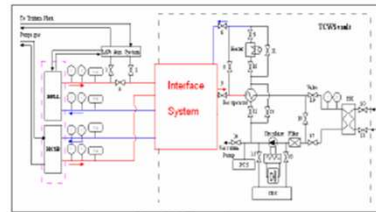

Layout for HCS sub-system

- ◆ Installed in TCWS;
- ◆ Common HCS for two TBMs;
- ◆ Two loops:
 - the primary helium circulation loop with all components,
 - the secondary heat removal loop
- ◆ A minimum net foot print size—about 90m², 5m height ;

Tritium Extraction Systems (TES)

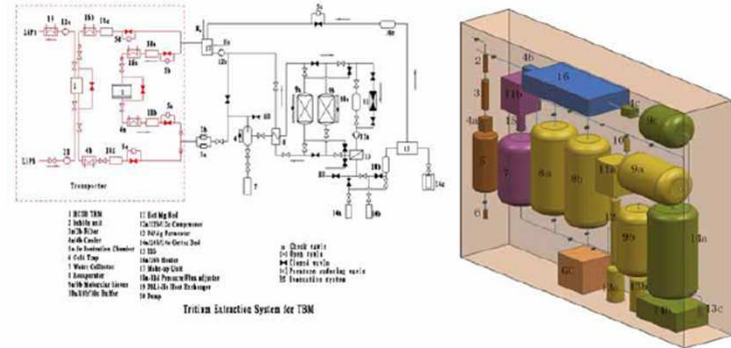

Flow chart and Layout Tritium Extraction System (TES)

TES is to remove the tritium produced in TBM and to control the gas composition of the low-pressure purge gas. For reasons of radiological safety, the system must be installed in a glove box.

Coolant Purification Systems (CPS)

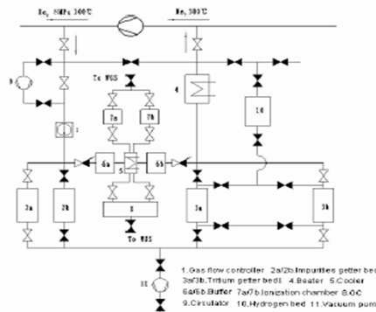

Flow chart and layout of Coolant Purification System (CPS)

The CPS is connected to the helium cooling loop at both sides of the circulator of HCS in parallel. For safety purpose, the system must be installed in a glove box as secondary containment

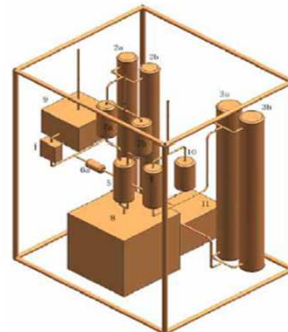

Tritium Measurement System (TMS)

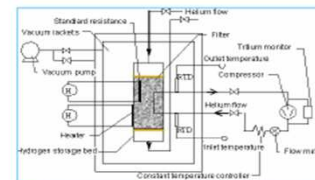

The schematic of the gas flow calorimeter

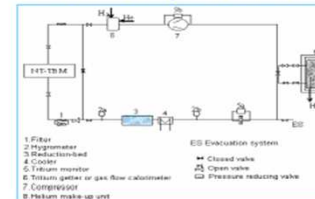

Flow chart of the TMS

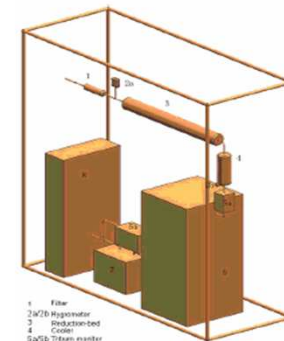

Layout of the TMS

Progress on Ceramic Breeder and Beryllium Pebbles R&D

- Two kinds of ceramic breeders (Li_4SiO_4 , Li_2TiO_3) for HCCB TBM are being developed at different institutions in China;
- Lithium orthosilicate (Li_4SiO_4) pebbles will be the primary option in the CN HCCB TBM. The Li_2TiO_3 will be a candidate tritium breeder.



- Melt spraying method for Li_4SiO_4 have good sphericity, and high density.
- Freeze-sintering process for Li_4SiO_4 have good mechanical properties ;
- Sol-gel method for Li_2TiO_3 Pebbles have good surface feature .

Main properties (Li_4SiO_4) by melt spraying method

Relative density	94% TD
Li_4SiO_4 phase content	≥90%
Closed porosity	0.72%
Open porosity	5.2 %
Average crush load	7.0 N
Specific surface area	1.092 m ² /g



Li_2TiO_3 Pebbles (D=1mm) by Sol-gel method@CAEP

Beryllium Pebbles R&D

- ❑ Be metal of high performance has been developed in China .
- ❑ Be pebbles have been produced by Rotating Electrode Process (REP) method in China. Related performance tests are on going.
- ❑ A new project to develop higher quality Be pebbles in China has being implemented for the ITER project.

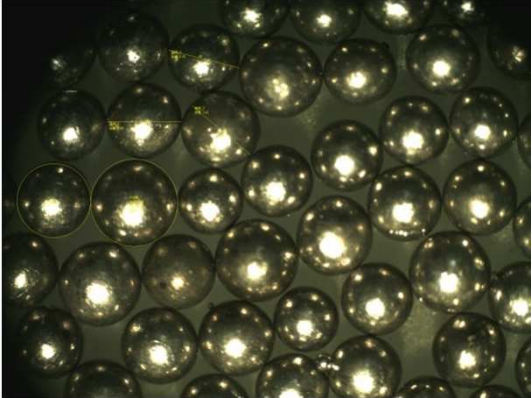

Micrographs of Be Pebbles (D=1mm)



REP Facility at HBSM Co.

Development of Helium Coolant Test Loop

✚ The construction of a small He Test Loop to validate circulator technology will be completed this year.
 - The He test loop has two impellers. It uses aerostatic bearings to avoid oil lubricating.

Main parameters of circulator design

Parameters	Maximum flow rate /kg ⁻¹ s	Inlet pressure /MPa	Maximum pressure head /MPa	He inlet/outlet temperature /°C
Circulator	~0.35	8	0.4	~50/65

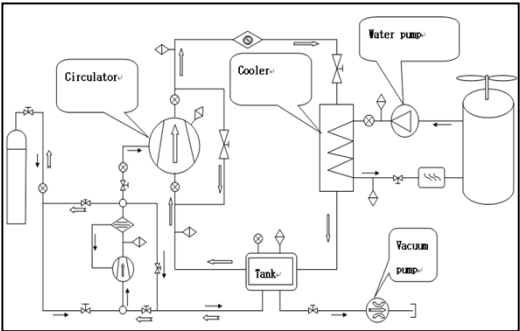

Flow diagram of small He loop



Fabrication of Impeller



Impeller of circulator

● A prototyped Helium Test Loop to validate TBM components and design is also to be built in SWIP. The flow rate will up to 1.3kg/s.

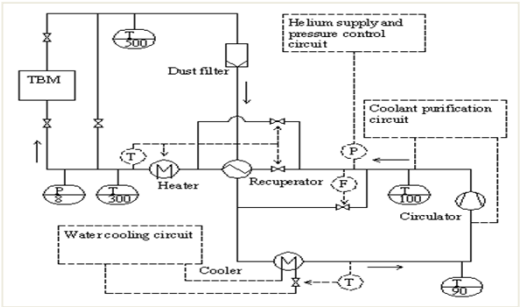

Flow diagram of He Loop

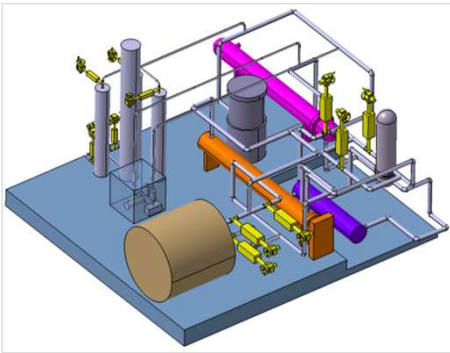

Layout of He Loop

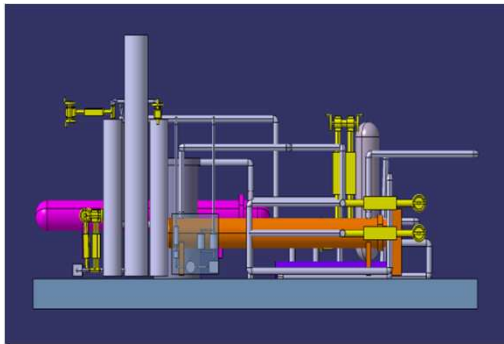

Cross-section view

Progress on Structural Materials-CLF-1 and Fabrication R&D

- Two RAFM alloys have been developed in China; CLF-1 in SWIP and CLAM in ASIPP
- 1-ton ingot of CLF-1 steel were recently produced by vacuum induction melting and electro-slag re-melting methods.
- The optimization of the melting technique for the larger ingots to 3 tons is underway.

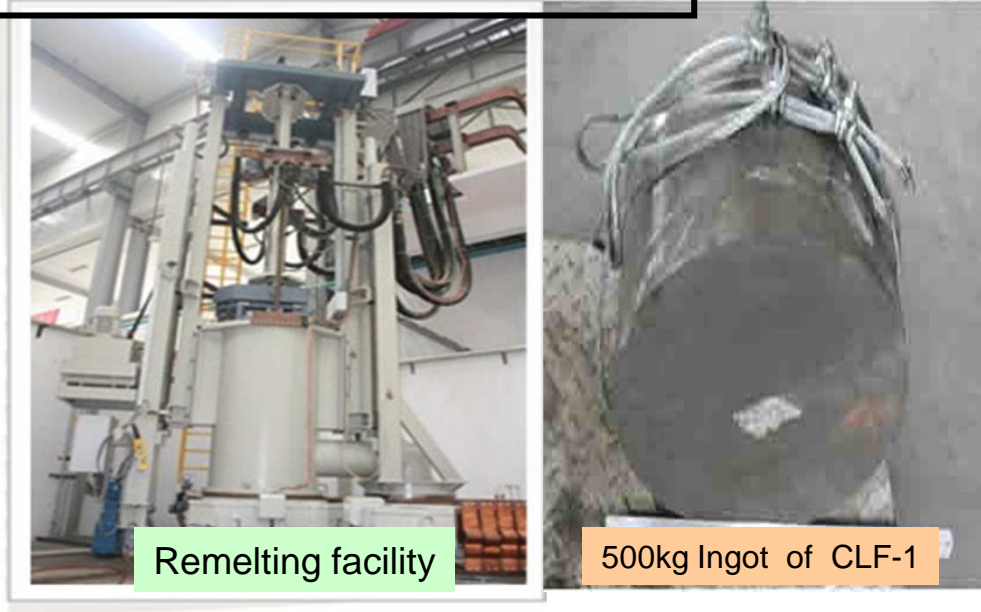

- A small-sized mock-up of U-shaped first wall is completed;
- Two kinds of fabrication method (EBW, HIP) of U-shaped FW have been considered;
- Full sized mock-up of U-shaped first wall is under way.

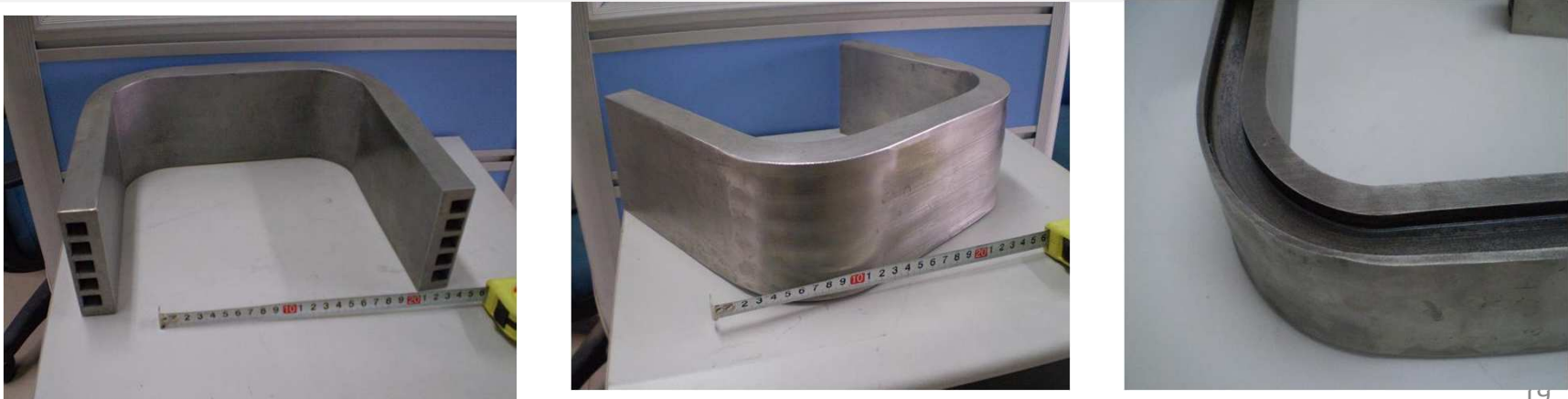

Fabrication Process of U-Shaped FW

Indian Lead-Lithium Ceramic Breeder Test Blanket System (LLCB-TBS)

Indian LLCB TBM

IN-TBM

LLCB

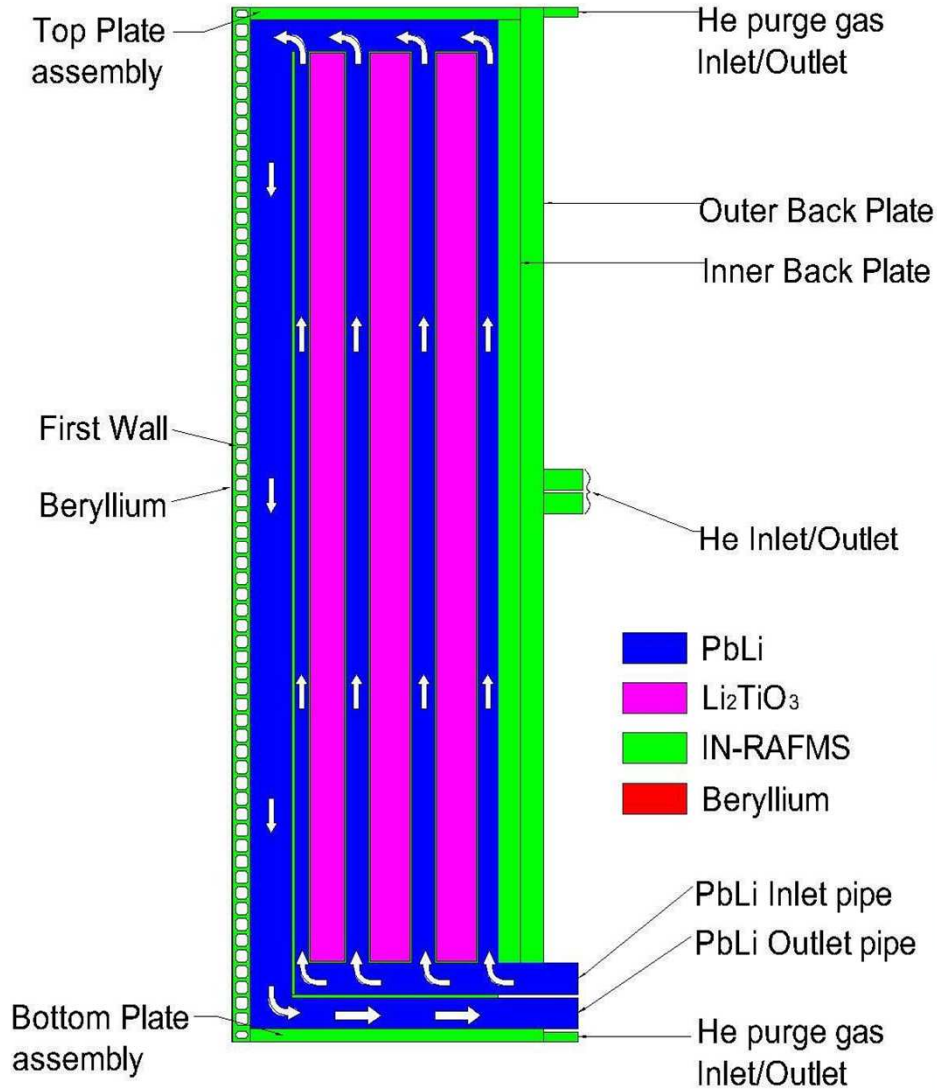

- PbLi
- Li₂TiO₃
- IN-RAFMS
- Beryllium

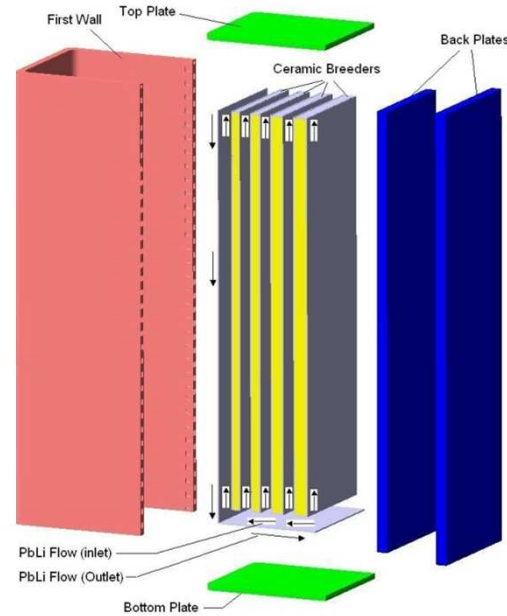
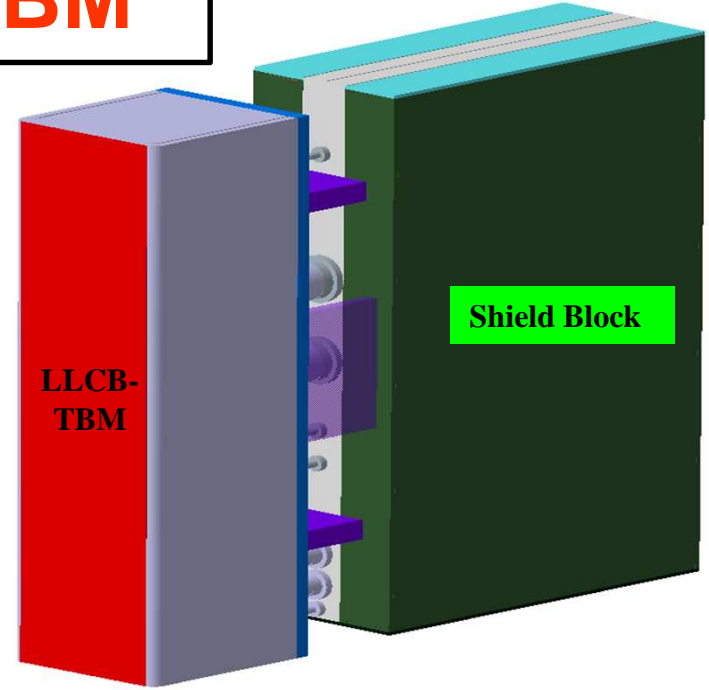

Structural Material	IN-RAFMS
Breeder	Pb-Li, Li ₂ TiO ₃
Coolants	Helium & Pb-Li
Helium Inlet/Outlet Temp.	300 – 400 C
Helium Pressure	80 bar
Pb-Li Inlet/outlet Temp.	300-450 C
T Purge gas	Helium/ 1.2 bar

IN LLCB TBS Auxiliary Systems

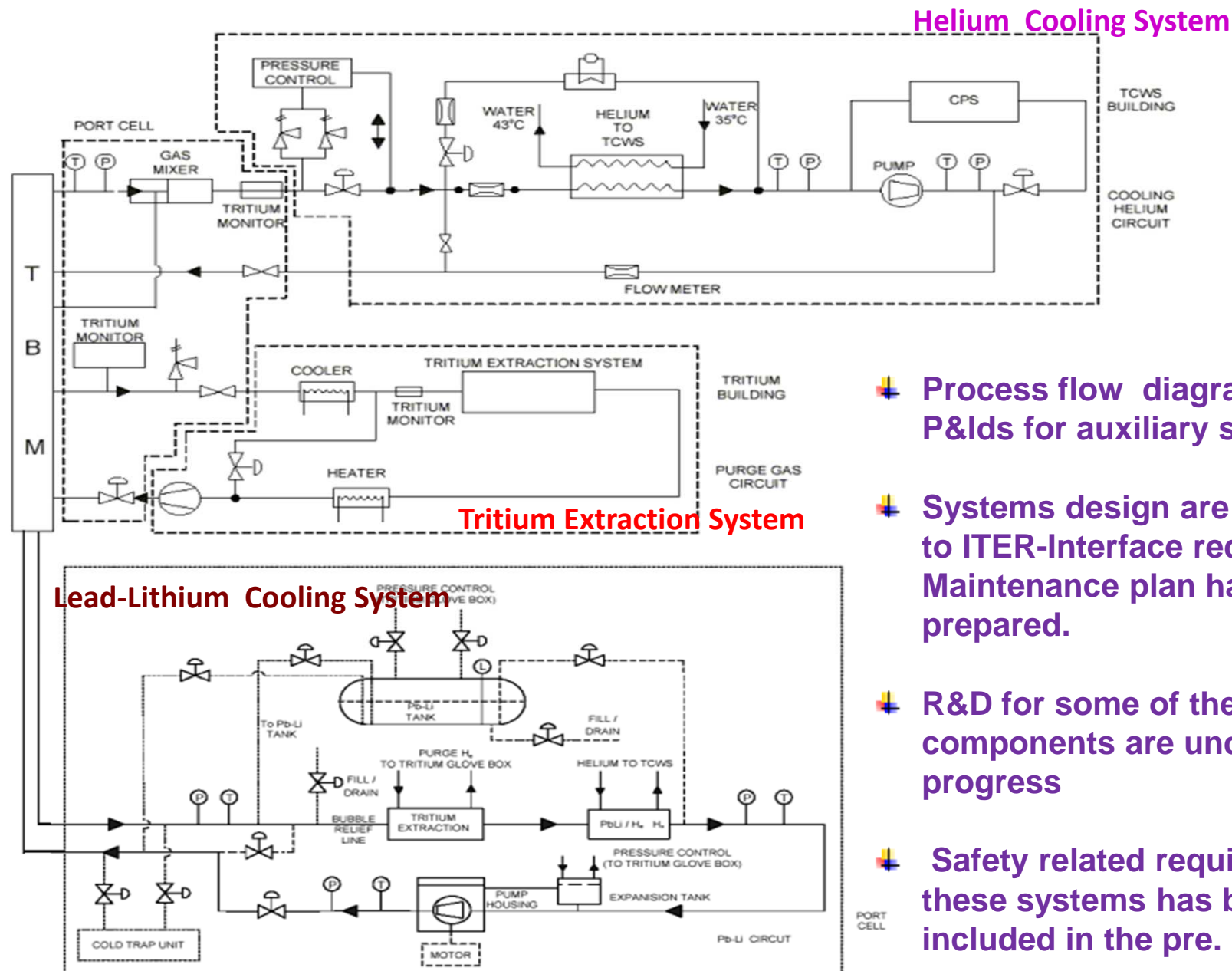

- Process flow diagrams and P&IDs for auxiliary systems
- Systems design are according to ITER-Interface requirements. Maintenance plan has been prepared.
- R&D for some of the critical components are under progress
- Safety related requirements for these systems has been included in the pre. RPRS

Liquid Metal R&D Activities

Pb-Li Corrosion loop at IPR



Lead-lithium Diagnostics Development



Lead-lithium Production



Joint MHD Experiments with IPUL, Latvia

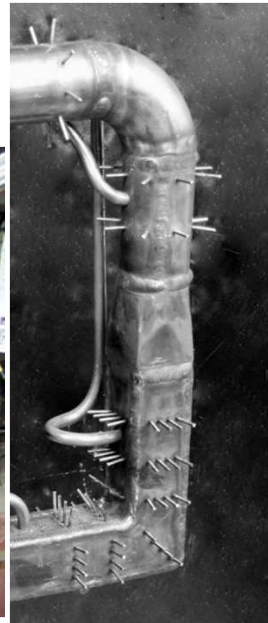
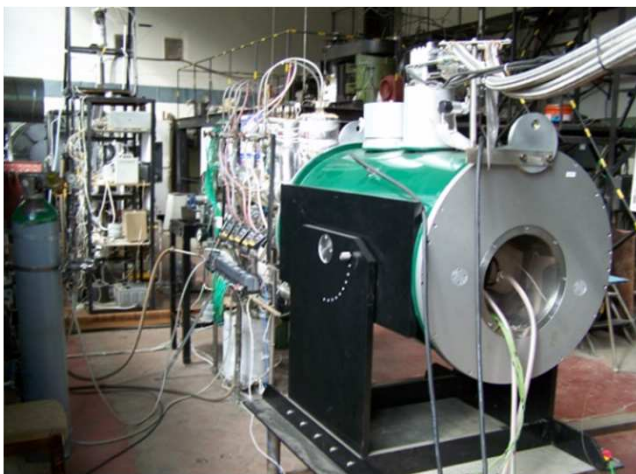

- SS316 L Test sections: Rectangular, circular flow cross-sections, 90° bends, rectangular to circular flow transition.
- Validation of MHD numerical code

Lithium Titanate Pebbles R&D in India

IN-TBM

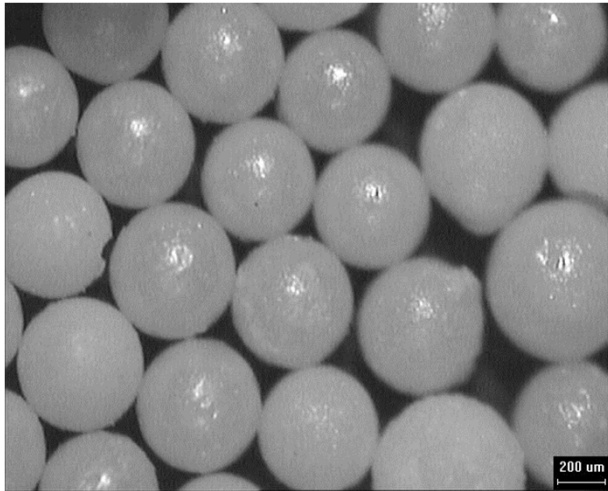

Photomicrograph of Li_2TiO_3 after sintering at 1250°C , 4 hours, by SOL-GEL Process:



After sintering at 1000°C , 6 hours, by Solution Combustion Process

Process development for the synthesis and fabrication of pebbles to meet the specifications for TBM and characterization.

1. Sol-Gel Process
2. Solid State Reaction, Extrusion & Spherodization
3. Solution Combustion Process, Extrusion & Spherodization



Sr.	Specifications	Target	Achieved
1.	Spherical shape with Diameter range	0.2-1.2 mm	~ 0.2 – 1.2 mm
2.	Density	3.2 g/cm ³	3.17-3.02 g/cm ³
3.	Density (TD %)	90 %	88-90%
4.	Lithium Density	0.4 g/cm ³	0.4g/cm ³
5.	Open Porosity (%)	7 %	7 %
6.	Closed Porosity (%)	5 %	5 %
7.	Grain Size	1 – 6 µm	1.2-2µm
8.	Surface area (BET)	0.18 m ² /g	0.13 m ² /g
9.	Thermal Conductivity@ 500 ^o	2.5 W/m K	Yet to be confirmed
10.	Thermal Expansion @ 500 C (delta L/L _o)	0.8 %	Yet to be done
11.	Crushing Load	15 - 45 N/m ²	16 – 20 N/m ²

IN-RAFMS & Fabrication Technologies Development

- ✓ 3 nos. of 3 ton melts completed
- ✓ Chemical Composition under control
- ✓ RAFMS filler wire development completed



IN-RAFMS INGOT



Forging of IN-RAFMS

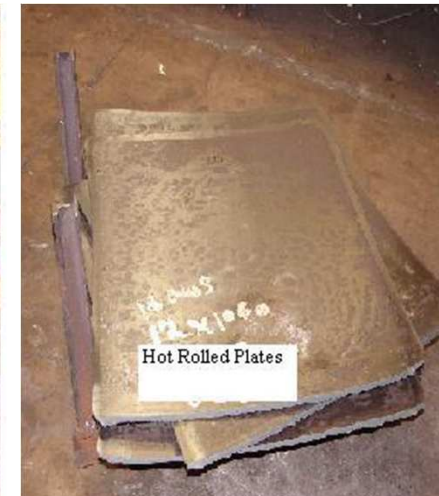

IN-RAFMS Plates

**First Wall Mock-up
for HIP Trials**

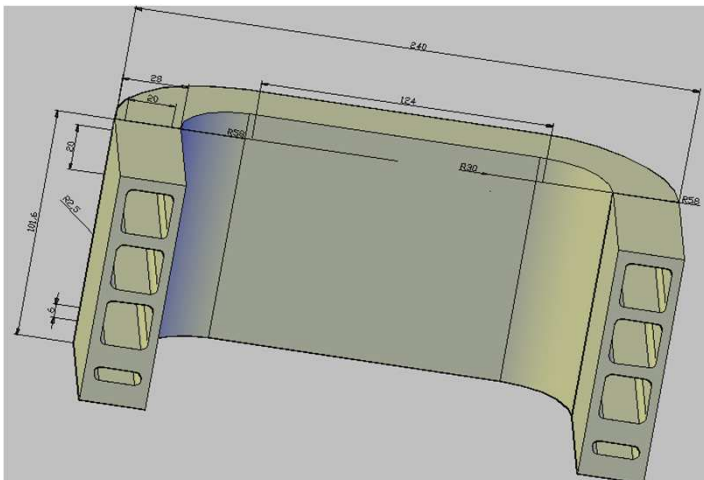

**First Wall Mock-up fabrication
by Laser Welding**



**L-Shaped He Channels
in the Back Plate**



ITER Operation and TBM Testing Programme

TBM

Complete Tokamak Core Construction

First Plasma

Hydrogen Helium Phase Complete

Deuterium Phase Complete

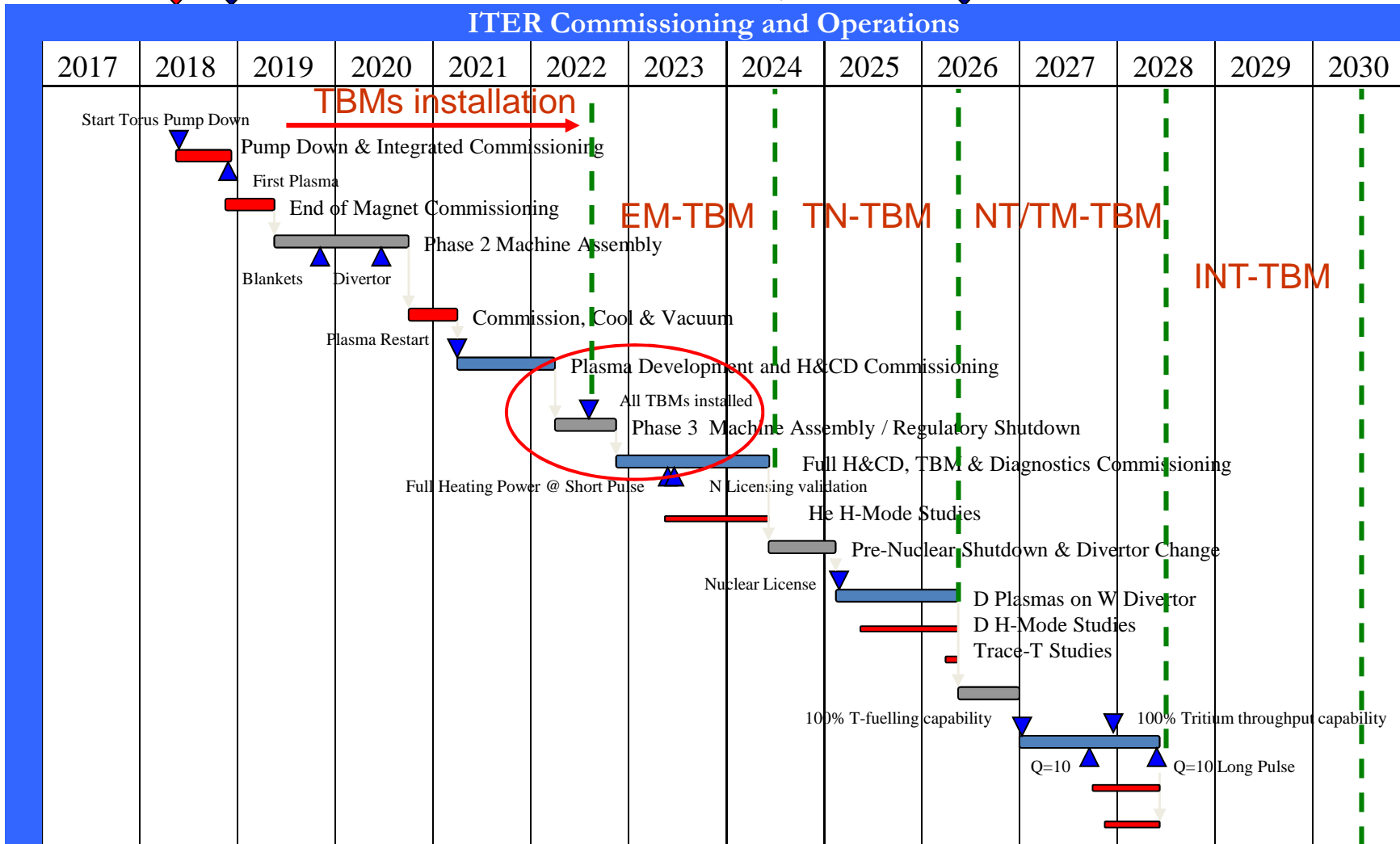

Summary

- ✚ ITER-TBM program is essential to:
 - Achieve a key element of the ITER Mission “demonstrate the scientific and technological feasibility of fusion power for peaceful purposes”
 - Achieve the most critical milestone in fusion nuclear technology research: testing in the integrated fusion environment.

- ✚ CN, EU, JA, KO, and IN are committed to deliver their TBM Systems for testing in ITER from the first phase of ITER operation

- ✚ R&D work in major areas such as, structural material characterization (mechanical properties, qualification of production processes), fabrication technologies, Lead-Lithium loop components, and tritium recovery & accounting systems are in full swing at EU, CN & IN TBM programs.

- ✚ Generic TBMA has been finalized and approved by ITER Council. IMs planning to install the TBS are preparing their individual TBMA for signature.

Thank you